

INTRODUCTION TO TORIC VARIETIES

Jean-Paul Brasselet
IML Luminy Case 907
F-13288 Marseille Cedex 9
France
`jpb@iml.univ-mrs.fr`

The course given during the School and Workshop “The Geometry and Topology of Singularities”, 8-26 January 2007, Cuernavaca, Mexico is based on a previous course given during the 23o Colóquio Brasileiro de Matemática (Rio de Janeiro, July 2001). It is an elementary introduction to the theory of toric varieties. This introduction does not pretend to originality but to provide examples and motivation for the study of toric varieties. The theory of toric varieties plays a prominent role in various domains of mathematics, giving explicit relations between combinatorial geometry and algebraic geometry. They provide an important field of examples and models. The Fulton’s preface of [11] explains very well the interest of these objects “*Toric varieties provide a ... way to see many examples and phenomena in algebraic geometry... For example, they are rational, and, although they may be singular, the singularities are rational. Nevertheless, toric varieties have provided a remarkably fertile testing ground for general theories.*”

Basic references for toric varieties are [10], [11] and [15]. These references give complete proofs of the results and descriptions. They were (abusively) used for writing these notes and the reader can consult them for useful complementary references and details.

Various applications of toric varieties can be found in the litterature, in particular in the book [11]. Interesting applications and suitable references are given in [7]: applications to Algebraic coding theory, Error-correcting codes, Integer programming and combinatorics, Computing resultants and solving equations, including the study of magic squares (see 8.3). Applications to Symplectic Manifolds are given in [1]. Of course this list is not exhaustive.

Special thanks to Gottfried Barthel, Karl-Heinz Fieseler and Ludger Kaup: in their friendly company, I discovered the wonderful country of toric varieties and thanks to them I was able to write these notes.

Marseille, 29 December 2006

Contents

1	From combinatorial geometry to toric varieties	3
1.1	Cones	3
1.2	Faces	4
1.3	Monoids	6
2	Affine toric varieties	9
2.1	Laurent polynomials	9
2.2	Some basic results of algebraic geometry	9
2.3	Affine toric varieties	10
3	Toric Varieties	16
3.1	Fans	16
3.2	Toric varieties	17
3.3	More examples	18
3.4	Geometric and Topological Properties of Toric varieties	20
4	The torus action and the orbits.	22
4.1	The torus action	22
4.2	Orbits	22
4.3	Toric varieties and fans	26
4.4	Toric variety associated to a polytope	29
5	Divisors and homology	32
5.1	Divisors	32
5.2	Support functions and divisors.	34
5.3	Divisors, homology and cohomology.	35
6	Resolution of singularities	36
6.1	The Hirzebruch surface	36
6.2	Toric surfaces	37
6.3	Playing with multiplicities	38
6.4	Resolution of singularities	40
7	More algebraic geometry	45
7.1	Poincaré homomorphism.	45
7.2	Betti cohomology numbers	46
7.3	Betti homology numbers	47
7.4	Characteristic classes.	47
8	Examples of applications	49
8.1	Sommerville relations	49
8.2	Lattice points in a polytope	50
8.3	Magic squares	52

1 From combinatorial geometry to toric varieties

The procedure of the construction of (affine) toric varieties associates to a cone σ in the Euclidean space \mathbb{R}^n successively: the dual cone $\check{\sigma}$, a monoid S_σ , a finitely generated \mathbb{C} -algebra R_σ and finally an algebraic variety X_σ . In the following, we describe the steps of this procedure :

$$\sigma \mapsto \check{\sigma} \mapsto S_\sigma \mapsto R_\sigma \mapsto X_\sigma$$

and recall some useful definitions and results of algebraic geometry.

1.1 Cones

Let $A = \{v_1, \dots, v_r\}$ be a finite set of vectors in \mathbb{R}^n , the set

$$\sigma = \{x \in \mathbb{R}^n : x = \lambda_1 v_1 + \dots + \lambda_r v_r, \quad \lambda_i \in \mathbb{R}, \quad \lambda_i \geq 0\}$$

is called a polyhedral cone. The vectors v_1, \dots, v_r are called generators of the cone σ .

If $A = \emptyset$ then $\sigma = \{0\}$ is the zero cone.

Example 1.1 In \mathbb{R}^2 with canonical basis (e_1, e_2) , one has the following cones :

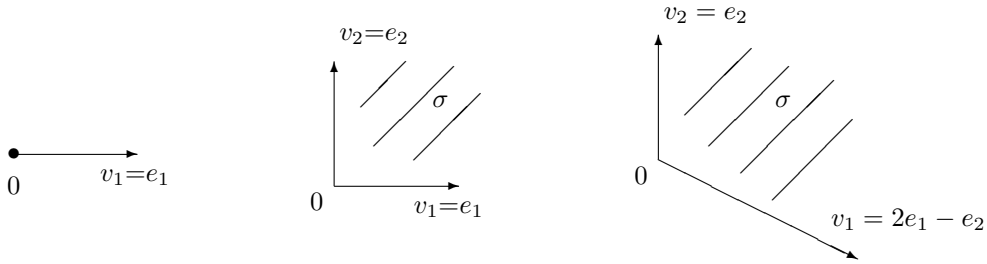

Fig. 1. Examples of cones

The *dimension* of σ , denoted $\dim \sigma$, is the dimension of the smallest linear space containing σ .

In the following, N will denote a fixed lattice $N \cong \mathbb{Z}^n \subset \mathbb{R}^n$.

Definition 1.1 A cone σ is a lattice (or rational) cone if all the generators v_i of σ belong to N .

A cone is *strongly convex* if it does not contain any straight line going through the origin (i.e. $\sigma \cap (-\sigma) = \{0\}$).

The first step of the procedure of construction of toric varieties is the definition of the dual cone associated to a cone. Let $(\mathbb{R}^n)^*$ be the dual space of \mathbb{R}^n and $\langle \cdot, \cdot \rangle$ the dual pairing. To each cone we associate the dual cone $\check{\sigma}$

$$\check{\sigma} = \{u \in (\mathbb{R}^n)^* : \langle u, v \rangle \geq 0 \quad \forall v \in \sigma\}$$

Example 1.2 Let us denote by (e_1^*, e_2^*) the canonical (dual) basis of $(\mathbb{R}^2)^*$. One has the examples:

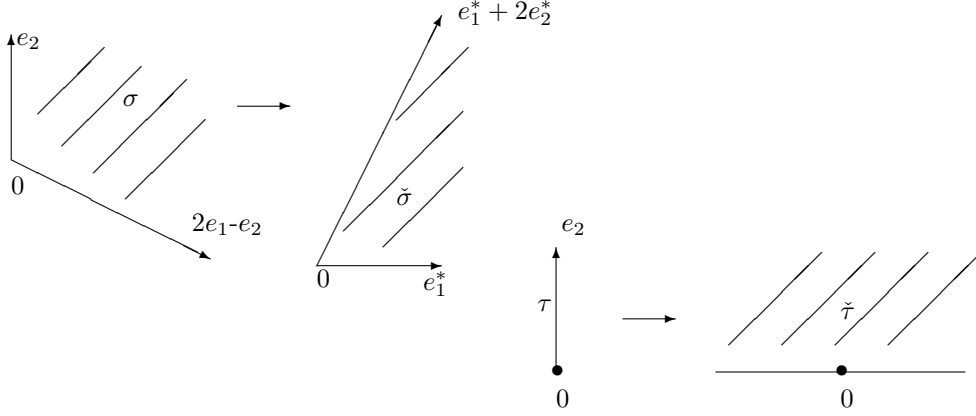

Fig. 2. Examples of dual cones

Given a lattice N in \mathbb{R}^n , we define the dual lattice $M = \text{Hom}_{\mathbb{Z}}(N; \mathbb{Z}) \cong \mathbb{Z}^n$ in $(\mathbb{R}^n)^*$ and we have the property :

Property 1.1 *If σ is a lattice cone, then $\check{\sigma}$ is a lattice cone (relatively to the lattice M).*

If σ is a polyhedral convex cone, then $\check{\sigma}$ is a polyhedral convex cone.

In fact, polyhedral cones σ can also be defined as intersections of half-spaces. Each (co)vector $u \in (\mathbb{R}^n)^*$ defines a half-space $H_u = \{v \in \mathbb{R}^n : \langle u, v \rangle \geq 0\}$. Let $\{u_i\}$, $i = 1, \dots, t$ denote a set of generators of $\check{\sigma}$ (as a cone), then

$$\sigma = \bigcap_{i=1}^t H_{u_i} = \{v \in \mathbb{R}^n : \langle u_1, v \rangle \geq 0, \dots, \langle u_t, v \rangle \geq 0\}$$

Let us notice that if σ is a strongly convex cone, then $\check{\sigma}$ is not necessarily a strongly convex cone (see τ in Example 1.2).

Lemma 1.1 *Let σ be a lattice cone generated by the vectors (v_1, \dots, v_r) , then $\check{\sigma} = \bigcap \check{\tau}_i$ where τ_i is the ray generated by the vector v_i .*

1.2 Faces

Definition 1.2 *Let σ be a cone and let $\lambda \in \check{\sigma} \cap M$, then*

$$\tau = \sigma \cap \lambda^\perp = \{v \in \sigma : \langle \lambda, v \rangle = 0\}$$

is called a face of σ . We will write $\tau < \sigma$.

This definition coincides with the intuitive one (Exercise).

A cone is a face of itself, other faces are called proper faces.

An one dimensional face is called an *edge*.

Property 1.2 *Let σ be a rational polyhedral convex cone, then*

- (i) *Every face $\tau = \sigma \cap \lambda^\perp$ is a rational polyhedral convex cone.*
- (ii) *Every intersection of faces of σ is a face of σ .*

(iii) *Every face of a face is a face.*

PROOF: (i) is easy exercise. In fact, if $\{v_i\}$ is a set of generators of the cone σ , the cone τ is generated by those among vectors v_i for which $\langle \lambda, v_i \rangle = 0$.

(ii) comes from the relation

$$\bigcap_i (\sigma \cap \lambda_i^\perp) = \sigma \cap \left(\sum_i \lambda_i \right)^\perp$$

for $\lambda_i \in \check{\sigma}$.

(iii) If $\tau = \sigma \cap \lambda^\perp$ and $\gamma = \tau \cap \lambda'^\perp$, for $\lambda \in \check{\sigma}$ and $\lambda' \in \check{\tau}$, then for sufficiently large positive p , one has $\lambda' + p\lambda \in \check{\sigma}$ and $\gamma = \sigma \cap (\lambda' + p\lambda)^\perp$. \square

Remark 1.1 If $\tau < \sigma$, then $\check{\tau} \subset \check{\sigma}$ (Easy exercise).

Remark 1.2 If $\sigma = \sigma_1 + \sigma_2$, then $\check{\sigma} = \check{\sigma}_1 \cap \check{\sigma}_2$.

Property 1.3 If $\tau = \sigma \cap \lambda^\perp$ (with $\lambda \in \check{\sigma}$) is a face of σ , then

$$\check{\tau} = \check{\sigma} + \mathbb{R}_{\geq 0}(-\lambda).$$

PROOF: As the two sides of the formula are polyedral convex cones (because $\lambda \in \check{\sigma}$), it is sufficient to show that their duals coincide. On the one hand $(\check{\tau})^\vee = \tau$, on the other hand $(\check{\sigma} + \mathbb{R}_{\geq 0}(-\lambda))^\vee = \sigma \cap (-\lambda)^\vee = \sigma \cap \lambda^\perp = \tau$. Let us explicit the second equality: if $v \in \sigma \cap (-\lambda)^\vee$, then $\langle v, -\lambda \rangle \geq 0$ because $v \in (-\lambda)^\vee$ and $\langle v, \lambda \rangle \geq 0$ because $v \in \sigma$ and $\lambda \in \check{\sigma}$, then $\langle v, \lambda \rangle = 0$, converse is obvious. \square

Example 1.3 Let us consider the following examples:

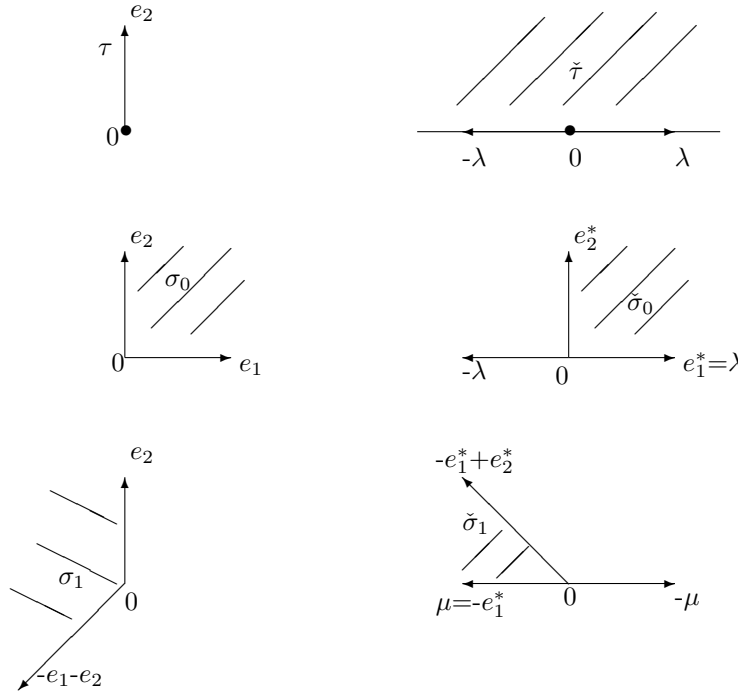

Fig. 3.

Firstly let us consider τ as a face of σ_0 . The vector $\lambda = e_1^*$ satisfies :

$$\lambda \in \check{\sigma}_0 \quad \tau = \sigma_0 \cap \lambda^\perp$$

and we have

$$\check{\tau} = \check{\sigma}_0 + \mathbb{R}_{\geq 0}(-\lambda).$$

Let us now consider τ as a face of the cone σ_1 . The vector $\mu = -e_1^*$ satisfies :

$$\mu \in \check{\sigma}_1 \quad \tau = \sigma_1 \cap \mu^\perp$$

and one has

$$\check{\tau} = \check{\sigma}_1 + \mathbb{R}_{\geq 0}(-\mu).$$

Finally let us consider the origin $\{0\}$ as a face of σ_0 :

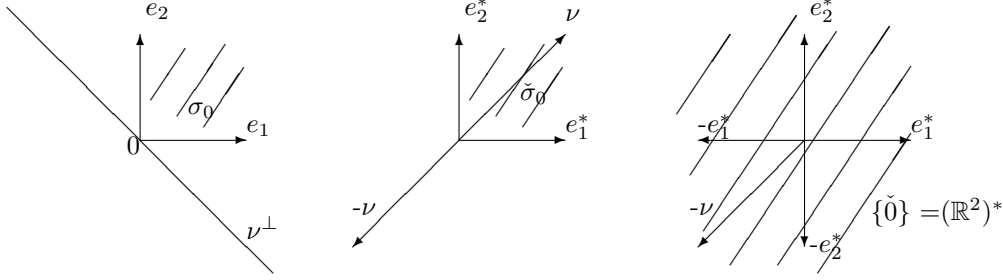

Fig. 4.

The vector $\nu = e_1^* + e_2^*$ satisfies :

$$\nu \in \check{\sigma}_0 \quad \{0\} = \sigma_0 \cap \nu^\perp$$

and one has

$$\check{\{0\}} = (\mathbb{R}^2)^* = \check{\sigma}_0 + \mathbb{R}_{\geq 0}(-\nu).$$

Definition 1.3 *The relative interior of a cone σ is the topological interior of the space $\mathbb{R} \cdot \sigma$ generated by σ . A point of the relative interior is obtained taking a strictly positive linear combination of $\dim(\sigma)$ linearly independent vectors among the generators of σ . If σ is a rational cone, these vectors can be elements of the lattice.*

For any vector v in σ , there is a face $\tau < \sigma$ such that v is in the relative interior of τ .

Property 1.4 *If $\tau < \sigma$, then $\check{\sigma} \cap \tau^\perp$ is a face of $\check{\sigma}$ with $\dim(\tau) + \dim(\check{\sigma} \cap \tau^\perp) = n$. This provides a one-to-one correspondence (with reverse order) between faces of σ and faces of $\check{\sigma}$.*

PROOF: Faces of $\check{\sigma}$ are cones $\check{\sigma} \cap v^\perp$ with $v \in (\check{\sigma})^\vee \cap N = \sigma \cap N$. If τ is the cone containing v in its relative interior, then $\check{\sigma} \cap v^\perp = \check{\sigma} \cap (\check{\tau} \cap v^\perp) = \check{\sigma} \cap \tau^\perp$, then every face of $\check{\sigma}$ is of the stated type.

The correspondence $\tau \mapsto \tau^* = \check{\sigma} \cap \tau^\perp$ reverses order and we have $\tau \subset (\tau^*)^*$, then $\tau^* = ((\tau^*)^*)^*$ and the correspondence is bijective. The rest is easy. \square

1.3 Monoids

Definition 1.4 *A semi-group (i.e. a non empty set S with an associative operation $+: S \times S \rightarrow S$) is called a monoid if it is commutative, has a zero element ($0 + s = s, \forall s \in S$) and satisfies the simplification law, i.e. :*

$$s + t = s' + t \Rightarrow s = s' \text{ for } s, s' \text{ and } t \in S$$

Lemma 1.2 *If σ is a cone, then $\sigma \cap N$ is a monoid.*

PROOF: If $x, y \in \sigma \cap N$, then $x + y \in \sigma \cap N$ and the rest is easily verified. \square

Definition 1.5 *A monoid S is finitely generated if there are elements $a_1, \dots, a_k \in S$ such that*

$$\forall s \in S, s = \lambda_1 a_1 + \dots + \lambda_k a_k \text{ with } \lambda_i \in \mathbb{Z}_{\geq 0}.$$

Elements a_1, \dots, a_k are called *generators* of the monoid.

Lemma 1.3 (*Gordon's Lemma*). *If σ is a polyhedral lattice cone, then $\sigma \cap N$ is a finitely generated monoid.*

PROOF: Let $A = \{v_1, \dots, v_r\}$ be the set of vectors defining the cone σ . Each v_i is an element of $\sigma \cap N$. The set $K = \{\sum t_i v_i, 0 \leq t_i \leq 1\}$ is compact and N is discrete, therefore $K \cap N$ is a finite set. We show that it generates $\sigma \cap N$. In fact, every $v \in \sigma \cap N$ can be written $v = \sum (n_i + r_i) v_i$ where $n_i \in \mathbb{Z}_{\geq 0}$ and $0 \leq r_i \leq 1$. Each v_i and the sum $\sum r_i v_i$ belong to $K \cap N$, so we obtain the result. \square

We will apply this lemma to the polyhedral lattice cone $\check{\sigma}$ and will denote by S_σ the monoid $\check{\sigma} \cap M$.

Example 1.4 In \mathbb{R}^2 , consider the 0-dimensional cone $\sigma = \{0\}$

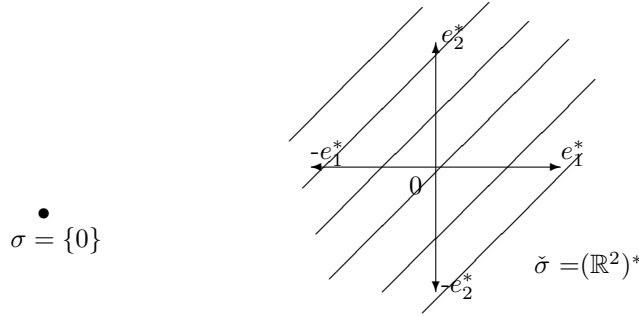

Fig. 5. The case $\sigma = \{0\}$.

In this example, $S_\sigma = \check{\sigma} \cap M$ is generated by the vectors $(e_1^*, -e_1^*, e_2^*, -e_2^*)$. It is also generated by $(e_1^*, e_2^*, -e_1^* - e_2^*)$.

Example 1.5 In \mathbb{R}^2 , consider the following cone

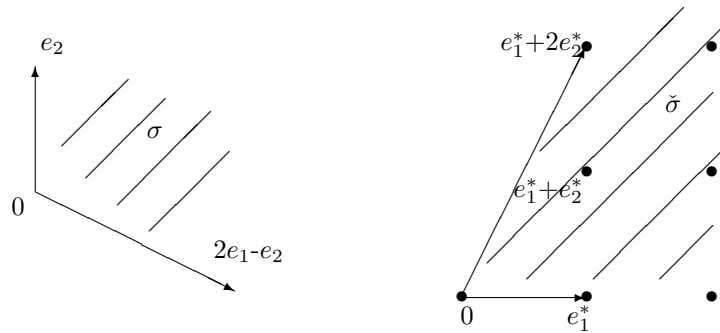

Fig. 6. A classical example.

In this example, $S_\sigma = \check{\sigma} \cap M$, marked \bullet , is not generated by the vectors e_1^* and $e_1^* + 2e_2^*$ alone. To obtain a set of generators, one has to add $e_1^* + e_2^*$. Then, S_σ is generated by $(e_1^*, e_1^* + e_2^*, e_1^* + 2e_2^*)$.

Proposition 1.1 *Let σ be a rational polyhedral convex cone and $\tau = \sigma \cap \lambda^\perp$ is a face of σ , with $\lambda \in S_\sigma = \check{\sigma} \cap M$, then*

$$S_\tau = S_\sigma + \mathbb{Z}_{\geq 0} \cdot (-\lambda).$$

PROOF: The proof is a direct consequence of Property 1.3 taking intersection of both sides with $M = \mathbb{Z}^n$. \square

Example 1.6 In the cases considered in Example 1.3, we obtain respectively:

For the face τ of σ_0 , the vector $\lambda = e_1^*$ satisfies $\check{\tau} = \check{\sigma}_0 + \mathbb{R}_{\geq 0}(-\lambda)$ and one has

$$S_\tau = S_{\sigma_0} + \mathbb{Z}_{\geq 0} \cdot (-\lambda)$$

If τ is considered as a face of σ_1 , the vector $\mu = -e_1^*$ satisfies $\check{\tau} = \check{\sigma}_1 + \mathbb{R}_{\geq 0}(-\mu)$ and one has

$$S_\tau = S_{\sigma_1} + \mathbb{Z}_{\geq 0} \cdot (-\mu)$$

Finally, let us consider the vertex $\{0\}$ as a face of σ_0 , the vector $\nu = e_1^* + e_2^*$ satisfies $\check{\{0\}} = \check{\sigma}_0 + \mathbb{R}_{\geq 0}(-\nu)$, and one has

$$S_{\{0\}} = S_{\sigma_0} + \mathbb{Z}_{\geq 0} \cdot (-\nu).$$

2 Affine toric varieties

2.1 Laurent polynomials

Let us denote by $\mathbb{C}[z, z^{-1}] = \mathbb{C}[z_1, \dots, z_n, z_1^{-1}, \dots, z_n^{-1}]$ the ring of Laurent polynomials. A Laurent monomial is written $\lambda \cdot z^a = \lambda z_1^{\alpha_1} \dots z_n^{\alpha_n}$, with $\lambda \in \mathbb{C}^*$ and $a = (\alpha_1, \dots, \alpha_n) \in \mathbb{Z}^n$. One of the important facts in the definition of toric varieties, and key of the second step, is the fact that the mapping

$$\begin{aligned} \theta : \mathbb{Z}^n &\rightarrow \mathbb{C}[z, z^{-1}] \\ a = (\alpha_1, \dots, \alpha_n) &\mapsto z^a = z_1^{\alpha_1} \dots z_n^{\alpha_n} \end{aligned}$$

is an isomorphism between the additive group \mathbb{Z}^n and the multiplicative group of monic Laurent monomials. Monic means that the coefficient of the monomial is 1. This isomorphism is easy to prove and let as an exercise.

Definition 2.1 *The support of a Laurent polynomial $f = \sum_{\text{finite}} \lambda_a z^a$ is defined by*

$$\text{supp}(f) = \{a \in \mathbb{Z}^n : \lambda_a \neq 0\}$$

Proposition 2.1 *For a lattice cone σ , the ring*

$$R_\sigma = \{f \in \mathbb{C}[z, z^{-1}] : \text{supp}(f) \subset \check{\sigma} \cap M\}$$

is a finitely generated monomial algebra (i.e. is a \mathbb{C} -algebra generated by Laurent monomials).

This result is a direct consequence of the Gordon's Lemma.

The following section recalls how we can associate to each finitely generated \mathbb{C} -algebra (in particular to R_σ) a coordinate ring, then an affine variety.

2.2 Some basic results of algebraic geometry

The proofs of results of this section can be found in [10] or [11] for example.

Let $\mathbb{C}[\xi] = \mathbb{C}[\xi_1, \dots, \xi_k]$ be the ring of polynomials in k variables over \mathbb{C} .

Definition 2.2 *If $E = (f_1, \dots, f_r) \subset \mathbb{C}[\xi]$, then*

$$V(E) = \{x \in \mathbb{C}^k : f_1(x) = \dots = f_r(x) = 0\}$$

is called the affine algebraic set defined by E .

Let I denote the ideal generated by E , then $V(I) = V(E)$.

Definition 2.3 *Let $X \subset \mathbb{C}^k$, then*

$$I(X) = \{f \in \mathbb{C}[\xi] : f|_X = 0\}$$

is an ideal, called the vanishing ideal of X .

Example 2.1 For $x = (x_1, \dots, x_k) \in \mathbb{C}^k$, let us consider $E = \{\xi_1 - x_1, \dots, \xi_k - x_k\}$. Then $V(E) = \{x\}$ and $I(\{x\}) = \mathbb{C}[\xi](\xi_1 - x_1) + \dots + \mathbb{C}[\xi](\xi_k - x_k)$. It is a maximal ideal denoted by \mathcal{M}_x (recall that an ideal \mathcal{M} is maximal if for each ideal \mathcal{M}' such that $\mathcal{M} \subset \mathcal{M}'$ then $\mathcal{M} = \mathcal{M}'$).

Let us remember that an ideal I in a ring R (commutative and with unit element 1) is maximal if and only if R/I is a field. As a corollary, every maximal ideal is prime.

Theorem 2.1 (*Weak version of the Nullstellensatz*) : Every maximal ideal in $\mathbb{C}[\xi]$ can be written \mathcal{M}_x for a point x .

Corollary 2.1 The correspondence $x \mapsto \mathcal{M}_x$ is a one-to-one correspondence between points in \mathbb{C}^k and maximal ideals \mathcal{M} of $\mathbb{C}[\xi]$.

$$\mathbb{C}^k \longleftrightarrow \{\mathcal{M} \subset \mathbb{C}[\xi], \mathcal{M} \text{ maximal ideal}\} =: \text{Spec}(\mathbb{C}[\xi])$$

Lemma 2.1 Let I be an ideal of $\mathbb{C}[\xi]$, then $V(I) = \{x \in \mathbb{C}^k : I \subset \mathcal{M}_x\}$.

Definition 2.4 Let us denote the vanishing ideal of $V(I)$ by $I_V = I(V(I))$, then $R_V = \mathbb{C}[\xi]/I_V$ is the coordinate ring of the affine algebraic set $V(I)$. It is generated as a \mathbb{C} -algebra by the classes $\bar{\xi}_j$ of the coordinate functions ξ_j .

The generators $\bar{\xi}_j = \xi_j + I_V$ of R_V are restrictions of coordinate functions to the affine algebraic set V .

We remark that if $I = \{0\}$, then $V(I) = \mathbb{C}^k$ and $R_V = \mathbb{C}[\xi]$. The Corollary 2.1, written for $I = \{0\}$, is generalized for any ideal in the following way:

Corollary 2.2 There is a one-to-one correspondence

$$V \longleftrightarrow \{\mathcal{M} \subset R_V, \mathcal{M} \text{ maximal ideal}\} =: \text{Spec}(R_V)$$

Defining the Zariski topology on each side (see, for example [10], VI.1), we obtain an homeomorphism

$$V \cong \text{Spec}(R_V)$$

Each commutative finitely generated \mathbb{C} -algebra R determines an affine complex variety $\text{Spec}(R)$. If generators of R are choosen, R can be written $\mathbb{C}[\xi_1, \dots, \xi_k]/I$ where I is an ideal. Then $\text{Spec}(R)$ is identified with the subvariety $V(I)$ in \mathbb{C}^k , which is the set of common zeroes of polynomials in I .

Remark 2.1 A finitely generated \mathbb{C} -algebra R can be written $\mathbb{C}[\xi_1, \dots, \xi_k]/I$, as a coordinate ring, for different k and ideals I . That means that we associate by this way, different affine algebraic sets $V(I) \in \mathbb{C}^k$. In fact, the Corollary 2.2 shows that these representations $V(I)$ are all homeomorphic to the variety $\text{Spec}(R_V)$.

2.3 Affine toric varieties

We are now able to define the affine toric variety associated to a cone σ :

Definition 2.5 The affine toric variety corresponding to a rational, polyhedral, strictly convex cone σ is $X_\sigma := \text{Spec}(R_\sigma)$.

The previous section shows that we can represent the finitely generated \mathbb{C} -algebra R_σ as a coordinate ring in different ways, according to a choice of generators of S_σ . Different choices provide different representations of the ‘‘abstract affine toric variety’’ $\text{Spec}(R_\sigma)$ in different complex spaces \mathbb{C}^k . In the following we will denote by X_σ such a representation. By Remark 2.1 they are all homeomorphic.

Let us explicit the construction by an example, then we will give the general case.

In the case of Example 1.5, let $a_1 = e_1^*$, $a_2 = e_1^* + e_2^*$ and $a_3 = e_1^* + 2e_2^*$ be a system of generators of S_σ . By the isomorphism θ , they correspond to monic Laurent monomials $u_1 = z_1$, $u_2 = z_1 z_2$ and $u_3 = z_1 z_2^2$. The \mathbb{C} -algebra R_σ can be represented as

$$R_\sigma = \mathbb{C}[u_1, u_2, u_3] = \mathbb{C}[\xi_1, \xi_2, \xi_3]/I_\sigma$$

where the relation $a_1 + a_3 = 2a_2$ provides the relation $u_1 u_3 = u_2^2$ between coordinates. The ideal I_σ is then generated by the binomial relation $\xi_1 \xi_3 = \xi_2^2$ and the affine toric variety corresponding to the cone σ is represented in \mathbb{C}^3 as the quadratic cone

$$X_\sigma = V(I_\sigma) = \{x = (x_1, x_2, x_3) \in \mathbb{C}^3 : x_1 x_3 = x_2^2\}$$

It has a singularity at the origin of \mathbb{C}^3 . The following picture gives the real part of X_σ in \mathbb{R}^3 .

Fig. 7. The quadratic cone

In the general case, the situation is the same : Let a_1, \dots, a_k be a system of generators of S_σ , where each a_i is written $a_i = (\alpha_i^1, \dots, \alpha_i^n) \in \check{\sigma} \cap M$. By the isomorphism θ , we obtain monic Laurent monomials $u_i = z^{a_i} = z_1^{\alpha_i^1} \dots z_n^{\alpha_i^n} \in \mathbb{C}[z, z^{-1}]$ for $i = 1, \dots, k$. The \mathbb{C} -algebra $R_\sigma = \mathbb{C}[u_1, \dots, u_k]$ can be represented by

$$R_\sigma = \mathbb{C}[\xi_1, \dots, \xi_k]/I_\sigma$$

for some ideal I_σ that we must determinate.

Relations between generators of S_σ are written

$$(*) \quad \sum_{j=1}^k \nu_j a_j = \sum_{j=1}^k \mu_j a_j \quad \mu_j, \nu_j \in \mathbb{Z}_{\geq 0} \quad ,$$

we obtain the monomial relations

$$(z^{a_1})^{\nu_1} \dots (z^{a_k})^{\nu_k} = (z^{a_1})^{\mu_1} \dots (z^{a_k})^{\mu_k}$$

where $z^{a_i} = (z_1^{\alpha_i^1}, \dots, z_n^{\alpha_i^n})$, i.e. relations

$$u_1^{\nu_1} \dots u_k^{\nu_k} = u_1^{\mu_1} \dots u_k^{\mu_k}$$

between the coordinates and finally the *binomial relations*

$$(**) \quad \xi_1^{\nu_1} \dots \xi_k^{\nu_k} = \xi_1^{\mu_1} \dots \xi_k^{\mu_k}$$

that generate I_σ .

Theorem 2.2 Let σ be a lattice cone in \mathbb{R}^n and $A = (a_1, \dots, a_k)$ a system of generators of S_σ , the corresponding toric variety X_σ is represented by the affine toric variety $V(I_\sigma) \subset \mathbb{C}^k$ where I_σ is an ideal of $\mathbb{C}[\xi_1, \dots, \xi_k]$ generated by finitely many binomials of the form $(**)$ corresponding to relations $(*)$ between elements of A .

PROOF: By Lemma 1.3, the monoid of all integral, positive, linear relations $(*)$ is finitely generated. The rest of the proof consists to show that every element of I_σ is a sum of binomials of the previous type (see [10], Theorem VI.2.7). \square

As a consequence of the Theorem 2.2, a point $x = (x_1, \dots, x_k) \in \mathbb{C}^k$ represents a point of X_σ if and only if the relation $x_1^{\nu_1} \cdots x_k^{\nu_k} = x_1^{\mu_1} \cdots x_k^{\mu_k}$ holds for all (ν, μ) appearing in the relation $(*)$.

Example 2.2 Let us consider the cone $\sigma = \{0\}$, the dual cone is $\check{\sigma} = (\mathbb{R}^n)^*$. We can choose different systems of generators of S_σ , for example

$$A_1 = (e_1^*, \dots, e_n^*, -e_1^*, \dots, -e_n^*)$$

or

$$A_2 = (e_1^*, \dots, e_n^*, -(e_1^* + \cdots + e_n^*)).$$

Let us take the first system of generators. The corresponding monomial \mathbb{C} -algebra is

$$\mathbb{C}[z_1, \dots, z_n, z_1^{-1}, \dots, z_n^{-1}] = \mathbb{C}[\xi_1, \dots, \xi_{2n}]/I_\sigma$$

where

$$I_\sigma = \mathbb{C}[\xi](\xi_1 \xi_{n+1} - 1) + \cdots + \mathbb{C}[\xi](\xi_n \xi_{2n} - 1)$$

hence $X_\sigma = V((\xi_1 \xi_{n+1} - 1), \dots, (\xi_n \xi_{2n} - 1))$.

For $n = 1$, the obtained variety is a complex hyperbola whose asymptotes are the axis $\xi_1 = 0$ and $\xi_2 = 0$. It can be projected bijectively on the axis $\xi_2 = 0$ and the image is \mathbb{C}^* :

Fig. 8.

In the general case ($n \geq 1$), and by the same way, X_σ is homeomorphic to

$$\mathbb{T} = \{(z_1, \dots, z_n) \in \mathbb{C}^n : z_i \neq 0, \quad i = 1, \dots, n\} = (\mathbb{C}^*)^n$$

using the projection $\mathbb{C}^{2n} \mapsto \mathbb{C}^n$ on the first coordinates.

With the second system of generators A_2 , we have $R_\sigma = \mathbb{C}[\xi_1, \dots, \xi_n, \xi_{n+1}]/I_\sigma$ where $I_\sigma = \mathbb{C}[\xi](\xi_1 \cdots \xi_n \xi_{n+1} - 1)$ and we obtain another realization of X_σ , homeomorphic to \mathbb{T} , now in \mathbb{C}^{n+1} .

Definition 2.6 The set $\mathbb{T} = (\mathbb{C}^*)^n$ is called the complex algebraic n -torus.

Remark 2.2 1. \mathbb{T} includes the real torus as : $\mathbb{T} \cong (S^1)^n \times (\mathbb{R}_{\geq 0})^n$.

2. \mathbb{T} is a closed subset of \mathbb{C}^{2n} but, as a subspace of \mathbb{C}^n , it is not closed.

Proposition 2.2 *Let σ be a lattice cone in \mathbb{R}^n , the affine toric variety X_σ contains the torus $\mathbb{T} = (\mathbb{C}^*)^n$ as a Zariski open dense subset.*

PROOF: Let (a_1, \dots, a_k) be a system of generators for the monoid S_σ and let $V(I_\sigma) \subset \mathbb{C}^k$ be a representation of X_σ . With the previous coordinates of \mathbb{R}^n , each a_i is written $a_i = (\alpha_i^1, \dots, \alpha_i^n)$ with $\alpha_i^j \in \mathbb{Z}$ and $t \in \mathbb{T}$ is written $t = (t_1, \dots, t_n)$ with $t_j \in \mathbb{C}^*$. The embedding $h: \mathbb{T} \hookrightarrow X_\sigma$ is given by

$$t = (t_1, \dots, t_n) \mapsto (t^{a_1}, \dots, t^{a_k}) \in V(I_\sigma) \cap (\mathbb{C}^*)^k \text{ where } t^{a_i} = t_1^{\alpha_i^1} \dots t_n^{\alpha_i^n} \in \mathbb{C}^*.$$

We prove that h is a bijection from $(\mathbb{C}^*)^n$ to $X_\sigma \cap (\mathbb{C}^*)^k$. As $h(t)$ satisfies the binomial relations, it is clear that $h(t) \in X_\sigma \cap (\mathbb{C}^*)^k$.

Let us show that h is injective. Let $a \in S_\sigma$ such that all points $a + e_i^*$ are in S_σ , with e_i^* basis of $(\mathbb{R}^n)^*$. The Laurent monomials $z^a = f_0(u)$, $z^{a+e_i^*} = f_i(u)$ are in $R_\sigma = \mathbb{C}[u] \subset \mathbb{C}[z, z^{-1}]$ (coordinate ring). Let $h(t) = x$ be a point in $X_\sigma \cap (\mathbb{C}^*)^k$, then $f_i(h(t)) = t_i t^a = t_i f_0(h(t))$ and the t_i are determined by $t_i = f_i(h(t))/f_0(h(t))$.

The map h is surjective. Any point $x \in X_\sigma \cap (\mathbb{C}^*)^k$ can be written

$$x = h(f_1(x)/f_0(x), \dots, f_n(x)/f_0(x))$$

as the f_i are non zero in the point x . □

Example 2.3 In the case of example 1.5, the embedding is given by

$$(t_1, t_2) \mapsto (t_1, t_1 t_2, t_1 t_2^2) \in V(I) \cap (\mathbb{C}^*)^3$$

From the Proposition 2.2, one obtains:

Property 2.1 *If σ is a lattice cone in \mathbb{R}^n , then $\dim_{\mathbb{C}} X_\sigma = n$.*

Example 2.4 Let $\sigma \in \mathbb{R}^2$ be the following cone



Fig. 9.

S_σ is generated by (e_1^*, e_2^*) , $R_\sigma = \mathbb{C}[\xi_1, \xi_2]$, then $I_\sigma = \{0\}$ and X_σ is \mathbb{C}^2 . The same result is obtained if σ is generated by a basis of the lattice N .

Example 2.5 Let $\tau \in \mathbb{R}^2$ be the following cone

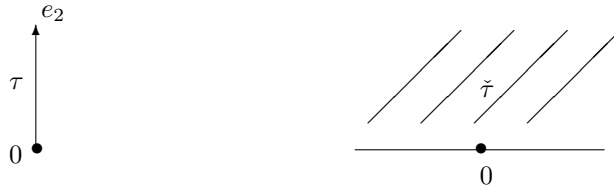

Fig. 10.

S_τ is generated by $(e_1^*, -e_1^*, e_2^*)$ and $R_\tau = \mathbb{C}[u_1, u_2, u_3]$ with $u_2 = u_1^{-1}$. One can write $R_\tau = \mathbb{C}[\xi_1, \xi_2, \xi_3]/(\xi_1 \xi_2 - 1)$ and X_τ is $\mathbb{C}_{\xi_1}^* \times \mathbb{C}_{\xi_2}$.

Example 2.6 Let $\sigma \in \mathbb{R}^3$ be the cone generated by e_1, e_2, e_3 and $a_4 = e_1 - e_2 + e_3$. Then S_σ is generated by $e_1^*, e_3^*, e_1^* + e_2^*$ and $e_2^* + e_3^*$,

$$R_\sigma = \mathbb{C}[u_1, u_3, u_1u_2, u_2u_3] = \mathbb{C}[\xi_1, \xi_2, \xi_3, \xi_4]/I_\sigma$$

where I_σ is generated by $\xi_1\xi_4 = \xi_2\xi_3$. The toric variety X_σ is an hypersurface in \mathbb{C}^4 defined by $x_1x_4 = x_2x_3$, i.e. a cone over a quadric surface.

Example 2.7 Let σ be the cone in \mathbb{R}^n generated by e_1, \dots, e_p , with $p \leq n$. Then S_σ is generated by $(e_1^*, \dots, e_p^*, e_{p+1}^*, -e_{p+1}^*, \dots, e_n^*, -e_n^*)$. One has

$$R_\sigma = \mathbb{C}[z_1, \dots, z_p, z_{p+1}, z_{p+1}^{-1}, \dots, z_n, z_n^{-1}]$$

and $X_\sigma = \mathbb{C}^p \times (\mathbb{C}^*)^{n-p}$. The same result is obtained if σ is generated by p vectors which are part of a basis of the lattice N .

Remark 2.3 Let us denote $N_{\mathbb{R}} = N \otimes_{\mathbb{Z}} \mathbb{R}$. A lattice homomorphism $\varphi : N' \rightarrow N$ defines an homomorphism of real vector spaces $\varphi_{\mathbb{R}} : N'_{\mathbb{R}} \rightarrow N_{\mathbb{R}}$. Assume that $\varphi_{\mathbb{R}}$ maps a (polyhedral, rational, strictly convex) cone σ' of N' in a (polyhedral, rational, strictly convex) cone σ of N . Then the dual map $\check{\varphi} : M \rightarrow M'$ provides a map $S_\sigma \rightarrow S_{\sigma'}$. It defines a map $R_\sigma \rightarrow R_{\sigma'}$ and a map $X_{\sigma'} \rightarrow X_\sigma$.

Let us apply the Remark to an Example:

Example 2.8 This is the example of an arbitrary 2-dimensional affine toric variety.

Let us consider in \mathbb{R}^2 the cone generated by e_2 and $pe_1 - qe_2$, for integers $p, q \in \mathbb{Z}_{>0}$ such that $0 < q < p$ and $(p, q) = 1$.

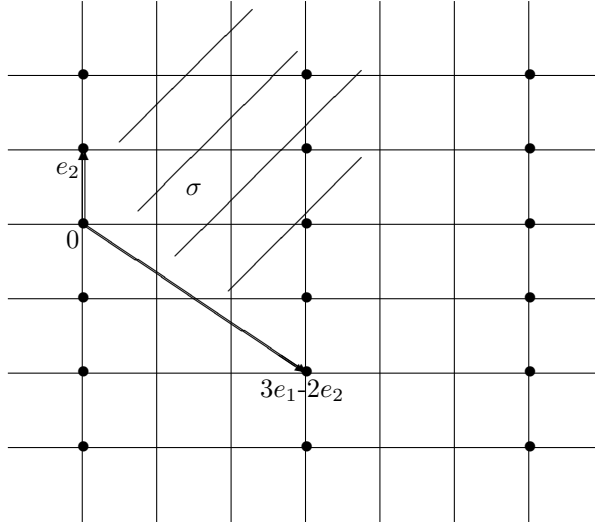

Fig. 11.

Then $R_\sigma = \mathbb{C}[\dots, z_1^i z_2^j, \dots]$ where the monoids $z_1^i z_2^j$ appear for all i and j such that $j \leq p/q i$. Let N' the sublattice of N generated by $pe_1 - qe_2$ and e_2 , i.e. by pe_1 and e_2 . In the figure 11, $p = 3$, $q = 2$ and N' is pictured by the points \bullet . Let us call σ' the cone σ considered in N' instead of N . Then σ' is generated by two generators of the lattice N' , so $X_{\sigma'}$ is \mathbb{C}^2 (cf. Example 2.4).

In such a situation, the inclusion $N' \subset N$ provides a map $X_{\sigma'} \rightarrow X_\sigma$ (Remark 2.3). This map can be explicitied in the following way:

Let us denote by x and y the monomials corresponding to the generators e_1^* and e_2^* of the dual lattice M . The dual lattice $M' \subset M$ corresponding to N' is generated by $\frac{1}{p}e_1^*$ and e_2^* . The monomials corresponding to these generators are u and y such that $u^p = x$. The monoid $S_{\sigma'}$ is generated by $\frac{1}{p}e_1^*$ and $\frac{1}{p}e_1^* + e_2^*$, then

$$R_{\sigma'} = \mathbb{C}[u, uy] = \mathbb{C}[u, v] \quad \text{with } v = uy$$

On the other hand, the monoid S_{σ} is generated by all $e_1^* + me_2^*$ with $0 \leq m \leq p$. Then

$$R_{\sigma} = \mathbb{C}[x, xy, \dots, xy^p] = \mathbb{C}[u^p, u^{p-1}v, \dots, uv^{p-1}, v^p] \subset \mathbb{C}[u, v]$$

and X_{σ} is the cone over the rational normal curve of degree p . The inclusion $R_{\sigma} \subset \mathbb{C}[u, v]$ induces a map

$$\text{Spec}(\mathbb{C}[u, v]) = X_{\sigma'} = \mathbb{C}^2 \rightarrow \text{Spec}(R_{\sigma}) = X_{\sigma}.$$

Here the group $\Gamma_p \cong \mathbb{Z}/p\mathbb{Z}$ of p -th roots of unity acts on $X_{\sigma'}$ by $\zeta \cdot (u, v) = (\zeta u, \zeta^q v)$ and then $X_{\sigma} = X_{\sigma'}/\Gamma_p = \mathbb{C}^2/\Gamma_p$ is a cyclic quotient singularity. The map $X_{\sigma'} \rightarrow X_{\sigma}$ is the quotient map.

The group of p -roots of unity acts on the coordinate ring $\mathbb{C}[u, v]$ in the following way $f \mapsto f(\zeta u, \zeta v)$. Then

$$R_{\sigma} = \mathbb{C}[u, v]^{\Gamma_p}$$

is the ring of invariants polynomials under the group action.

In a more general way, one has the following Lemma (see [11],2.2):

Lemma 2.2 *If $n = 2$, then singular affine toric varieties are cyclic quotient singularities.*

3 Toric Varieties

3.1 Fans

Definition 3.1 A fan Δ in the Euclidean space \mathbb{R}^n is a finite union of cones such that:

- (i) every cone of Δ is a strongly convex, polyhedral, lattice cone,
- (ii) every face of a cone of Δ is a cone of Δ ,
- (iii) if σ and σ' are cones of Δ , then $\sigma \cap \sigma'$ is a common face of σ and σ' .

In the following, unless specified, all cones we will consider will be strongly convex, polyhedral, lattice cones.

Example 3.1 Examples of fans:

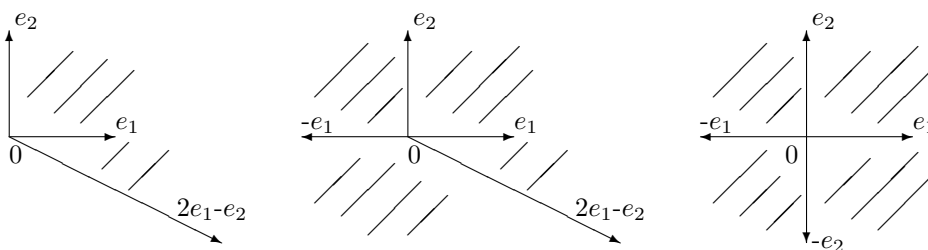

Fig. 12.

The toric varieties associated to fans will be constructed by gluing affine ones associated to cones. Let us begin by recalling a very simple example, the one of the projective space \mathbb{P}^2 .

Example 3.2 Let us denote by $(t_0 : t_1 : t_2)$ the homogeneous coordinates of the space \mathbb{P}^2 . It is classically covered by three coordinate charts:

U_0 corresponding to $t_0 \neq 0$, with affine coordinates $(t_1/t_0, t_2/t_0) = (z_1, z_2)$

U_1 corresponding to $t_1 \neq 0$, with affine coordinates $(t_0/t_1, t_2/t_1) = (z_1^{-1}, z_1^{-1}z_2)$

U_2 corresponding to $t_2 \neq 0$, with affine coordinates $(t_0/t_2, t_1/t_2) = (z_2^{-1}, z_1z_2^{-1})$

Now let us consider in \mathbb{R}^2 the following fan:

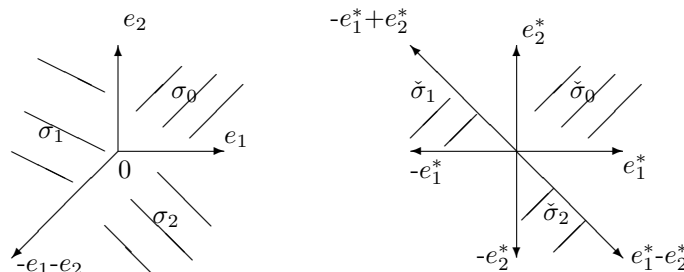

Fig. 13.

then :

i) S_{σ_0} admits as generators (e_1^*, e_2^*) , hence $R_{\sigma_0} = \mathbb{C}[z_1, z_2]$ and $X_{\sigma_0} = \mathbb{C}_{(z_1, z_2)}^2$ (Example 2.4);

ii) in the same way, $(-e_1^*, -e_1^* + e_2^*)$ is a system of generators of S_{σ_1} , hence $R_{\sigma_1} = \mathbb{C}[z_1^{-1}, z_1^{-1}z_2]$ and $X_{\sigma_1} = \mathbb{C}_{(z_1^{-1}, z_1^{-1}z_2)}^2$;

iii) finally, $(-e_2^*, e_1^* - e_2^*)$ is a system of generators of S_{σ_2} , hence $R_{\sigma_2} = \mathbb{C}[z_2^{-1}, z_1z_2^{-1}]$ and $X_{\sigma_2} = \mathbb{C}_{(z_2^{-1}, z_1z_2^{-1})}^2$.

We see that the three affine toric varieties correspond to the three coordinate charts of \mathbb{P}^2 . In fact, the structure of the fan provides a gluing between these charts allowing to reconstruct the toric variety \mathbb{P}^2 from the X_{σ_i} . Let us explicit the gluing of X_{σ_0} and X_{σ_1} “along” X_τ such that $\tau = \sigma_0 \cap \sigma_1$.

According to Examples 1.3 and 1.6, one has $S_\tau = S_{\sigma_0} + \mathbb{Z}_{\geq 0}(-e_1^*)$ and $S_\tau = S_{\sigma_1} + \mathbb{Z}_{\geq 0}(e_1^*)$. The affine toric variety X_τ is represented by $X_\tau = \mathbb{C}_{z_1}^* \times \mathbb{C}_{z_2}$ in $X_{\sigma_0} = \mathbb{C}_{(z_1, z_2)}^2$ and by $X_\tau = \mathbb{C}_{z_1^{-1}}^* \times \mathbb{C}_{z_1^{-1}z_2}$ in $X_{\sigma_1} = \mathbb{C}_{(z_1^{-1}, z_1^{-1}z_2)}^2$.

We can glue together X_{σ_0} and X_{σ_1} along X_τ using the change of coordinates $(z_1, z_2) \mapsto (z_1^{-1}, z_1^{-1}z_2)$. We obtain $\mathbb{P}^2 \setminus \{(0 : 0 : 1)\}$.

This example is a particular case of the general construction that we perform in the following section.

3.2 Toric varieties

In a general way, let τ be a face of a cone σ , then $S_\tau = S_\sigma + \mathbb{Z}_{\geq 0}(-\lambda)$ where $\lambda \in \check{\sigma} \cap M$ and $\tau = \sigma \cap \lambda^\perp$ (Proposition 1.1).

The monoid S_τ is thus obtained from S_σ by adding one generator $-\lambda$. As λ can be chosen as an element of a system of generators (a_1, \dots, a_k) for S_σ , we may assume that $\lambda = a_k$ is the last vector in the system of generators of S_σ and we denote $a_{k+1} = -\lambda$. In order to obtain the relationships between the generators of S_τ , one has to consider previous relationships between the generators (a_1, \dots, a_k) of S_σ and the supplementary relationship $a_k + a_{k+1} = 0$.

This relationship corresponds to the multiplicative one $u_k u_{k+1} = 1$ in R_τ and that is the only supplementary relationship we need in order to obtain R_τ from R_σ . As the generators u_i are precisely the coordinate functions on the toric varieties X_σ and X_τ , this means that the projection $\mathbb{C}^{k+1} \rightarrow \mathbb{C}^k$:

$$(x_1, \dots, x_k, x_{k+1}) \mapsto (x_1, \dots, x_k)$$

identifies X_τ with the open subset of X_σ defined by $x_k \neq 0$. This can be written :

Lemma 3.1 *There is a natural identification $X_\tau \cong X_\sigma \setminus (u_k = 0)$.*

Let us suppose that τ is the common face of two cones σ and σ' . The Lemma 3.1 allows us to glue together X_σ and $X_{\sigma'}$ “along” their common part X_τ . This is performed in the following way:

Let us write (v_1, \dots, v_l) the coordinates on $X_{\sigma'}$. By Lemma 3.1 there is an homeomorphism $X_\tau \cong X_{\sigma'} \setminus (v_l = 0)$ and we obtain a gluing map

$$\psi_{\sigma, \sigma'} : X_\sigma \setminus (u_k = 0) \xrightarrow{\cong} X_\tau \xrightarrow{\cong} X_{\sigma'} \setminus (v_l = 0).$$

Example 3.3 Let us return to the example of the projective space \mathbb{P}^2 , using the previous notations, one has:

With τ considered as a face of σ_0 , then $X_\tau = X_{\sigma_0} \setminus (z_1 = 0) = \mathbb{C}_{z_1}^* \times \mathbb{C}_{z_2}$. in $X_{\sigma_0} = \mathbb{C}_{(z_1, z_2)}^2$.

In the same way, τ being considered as a face of σ_1 , then $X_\tau = X_{\sigma_1} \setminus (z_1^{-1} = 0) = \mathbb{C}_{z_1^{-1}}^* \times \mathbb{C}_{z_1^{-1}z_2}$ in $X_{\sigma_1} = \mathbb{C}_{(z_1^{-1}, z_1^{-1}z_2)}^2$.

The gluing of X_{σ_0} and X_{σ_1} along X_τ is $\mathbb{P}^2 \setminus \{(0 : 0 : 1)\}$. Gluing this space by the same procedure with $X_{\sigma_2} = \mathbb{C}_{(z_2^{-1}, z_1z_2^{-1})}^2$, we obtain the total space \mathbb{P}^2 .

Theorem 3.1 (First Definition of Toric Varieties). *Let Δ be a fan in \mathbb{R}^n . Consider the disjoint union $\cup_{\sigma \in \Delta} X_\sigma$ where two points $x \in X_\sigma$ and $x' \in X_{\sigma'}$ are identified if $\psi_{\sigma, \sigma'}(x) = x'$. The resulting space X_Δ is called a toric variety. It is a topological space endowed with an open covering by the affine toric varieties X_σ for $\sigma \in \Delta$. It is an algebraic variety whose charts are defined by binomial relations.*

In fact, we have shown that, for a face τ of a cone σ , one has inclusions:

$$\begin{array}{ccc} \tau & \hookrightarrow & \sigma \\ \check{\tau} & \hookrightarrow & \check{\sigma} \\ R_\tau & \hookrightarrow & R_\sigma \\ X_\tau & \hookrightarrow & X_\sigma \end{array}$$

Before giving more examples, let us show a fundamental result :

Proposition 3.1 *Every n -dimensional toric variety contains the torus $\mathbb{T} = (\mathbb{C}^*)^n$ as a Zariski open dense subset.*

PROOF: The torus \mathbb{T} corresponds to the zero cone, which is a face of every $\sigma \in \Delta$, i.e. $\mathbb{T} = X_{\{0\}}$. The embedding of the torus into every affine toric variety X_σ has been shown in the Proposition 2.2. By the previous identifications, all the tori corresponding to affine toric varieties X_σ in X_Δ are identified as an open dense subset in X_Δ . \square

3.3 More examples

Here are some of the classical examples of toric varieties :

Example 3.4 Example of \mathbb{P}^2 can be generalized to \mathbb{P}^n considering, in \mathbb{R}^n , the fan Δ generated by all proper subsets of $(v_0, \dots, v_n) = (e_1, \dots, e_n, -(e_1 + \dots + e_n))$, i.e. σ_0 generated by (e_1, \dots, e_n) and for $i = 1, \dots, n$, the cone σ_i is generated by $(e_1, \dots, e_{i-1}, e_{i+1}, e_n, -(e_1 + \dots + e_n))$. The affine toric varieties X_{σ_i} are copies of \mathbb{C}^n , corresponding to classical charts of \mathbb{P}^n and glued together in order to obtain \mathbb{P}^n .

Example 3.5 Consider the following fan :

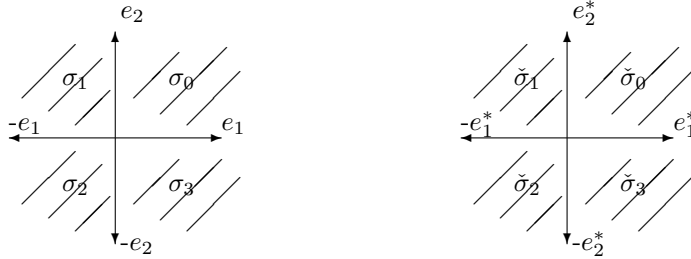

Fig. 14.

which gives the following monoids:

$$\begin{array}{ccc} S_{\sigma_1} \text{ gen. by } (-e_1^*, e_2^*) & \leftrightarrow & S_{\sigma_0} \text{ gen. by } (e_1^*, e_2^*) \\ \updownarrow & & \updownarrow \\ S_{\sigma_2} \text{ gen. by } (-e_1^*, -e_2^*) & \leftrightarrow & S_{\sigma_3} \text{ gen. by } (e_1^*, -e_2^*) \end{array}$$

and the following \mathbb{C} -algebra:

$$\begin{array}{ccc} R_{\sigma_1} = \mathbb{C}[z_1^{-1}, z_2] & \leftrightarrow & \mathbb{C}[z_1, z_2] = R_{\sigma_0} \\ \downarrow & & \downarrow \\ R_{\sigma_2} = \mathbb{C}[z_1^{-1}, z_2^{-1}] & \leftrightarrow & \mathbb{C}[z_1, z_2^{-1}] = R_{\sigma_3} \end{array}$$

The gluing of X_{σ_1} and X_{σ_0} gives $\mathbb{P}^1 \times \mathbb{C}$ with coordinates $((t_0 : t_1), z_2)$ where $(z_1 = t_0/t_1)$,

The gluing of X_{σ_2} and X_{σ_3} gives $\mathbb{P}^1 \times \mathbb{C}$ with coordinates $((t_0 : t_1), z_2^{-1})$,

The gluing of these two gives $X_\Delta = \mathbb{P}^1 \times \mathbb{P}^1$ with coordinates $((t_0 : t_1), (s_0 : s_1))$ where $(z_2 = s_0/s_1)$.

Example 3.6 Consider the following fan :

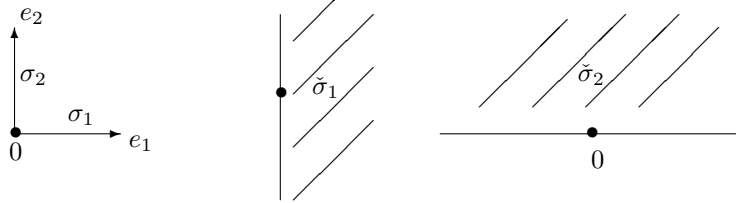

Fig. 15.

then S_{σ_1} is generated by $(e_1^*, e_2^*, -e_2^*)$. The monoid S_{σ_2} is generated by $(e_1^*, -e_1^*, e_2^*)$ and $S_{\{0\}}$ is generated by $(e_1^*, -e_1^*, e_2^*, -e_2^*)$. The corresponding \mathbb{C} -algebras are respectively $R_{\sigma_1} = \mathbb{C}[z_1, z_2, z_2^{-1}]$, $R_{\sigma_2} = \mathbb{C}[z_1, z_1^{-1}, z_2]$ and $R_{\{0\}} = \mathbb{C}[z_1, z_1^{-1}, z_2, z_2^{-1}]$. The corresponding affine toric varieties are $X_{\sigma_1} = \mathbb{C}_{z_1} \times \mathbb{C}_{z_2}^*$, $X_{\sigma_2} = \mathbb{C}_{z_1}^* \times \mathbb{C}_{z_2}$ and $X_{\{0\}} = \mathbb{C}_{z_1}^* \times \mathbb{C}_{z_2}^*$. The gluing of the affine toric X_{σ_1} and X_{σ_2} along $X_{\{0\}}$ gives $X_\Delta = \mathbb{C}^2 - \{0\}$.

Example 3.7 Consider the following fan :

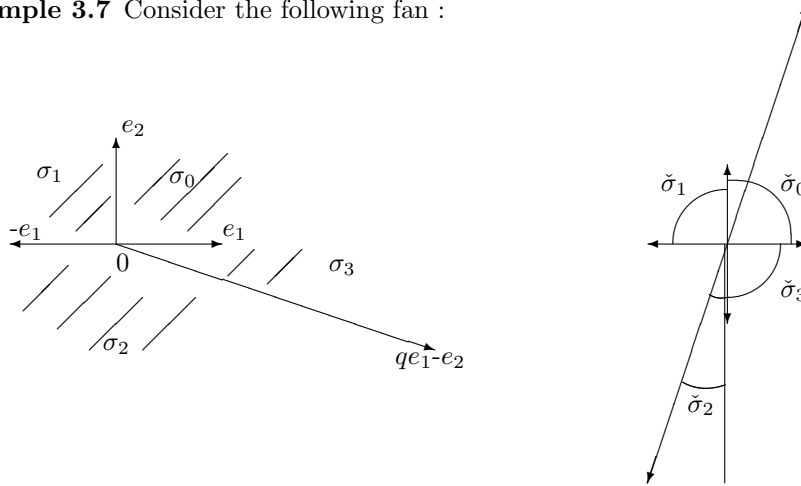

Fig. 16.

Then the monoids S_{σ_i} are generated:

$$\begin{array}{ccc} S_{\sigma_1} \text{ by } (-e_1^*, e_2^*) & \leftrightarrow & S_{\sigma_0} \text{ by } (e_1^*, e_2^*) \\ \downarrow & & \downarrow \\ S_{\sigma_2} \text{ by } (-e_1^* - qe_2^*, -e_2^*) & \leftrightarrow & S_{\sigma_3} \text{ by } (e_1^* + qe_2^*, -e_2^*) \end{array}$$

and the corresponding affine varieties are

$$\begin{array}{ccc} X_{\sigma_1} = \mathbb{C}^2_{(z_1^{-1}, z_2)} & \leftrightarrow & X_{\sigma_0} = \mathbb{C}^2_{(z_1, z_2)} \\ \downarrow & & \downarrow \\ X_{\sigma_2} = \mathbb{C}^2_{(z_1^{-1} z_2^{-q}, z_2^{-1})} & \leftrightarrow & X_{\sigma_3} = \mathbb{C}^2_{(z_1 z_2^q, z_2^{-1})} \end{array}$$

The gluing of X_{σ_1} and X_{σ_0} gives $\mathbb{P}^1 \times \mathbb{C}$ with coordinates $((t_0 : t_1), z_2)$ where $z_1 = t_0/t_1$, the gluing of X_{σ_2} and X_{σ_3} gives $\mathbb{P}^1 \times \mathbb{C}$ with coordinates $((s_0 : s_1), z_2^{-1})$ where $z_1 z_2^q = s_0/s_1$.

These two varieties, glued together, provide a \mathbb{P}^1 -bundle over \mathbb{P}^1 (identifying the second coordinates), which is a rational ruled surface denoted \mathcal{H}_q and called Hirzebruch surface. It is the hypersurface in $\mathbb{P}^1 \times \mathbb{P}^2$ defined by

$$\{(\lambda_0 : \lambda_1), (\mu_0 : \mu_1 : \mu_2) : \lambda_0^q \mu_0 = \lambda_1^q \mu_1\}$$

Example 3.8 Consider the following fan :

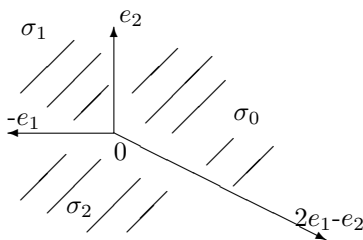

Fig. 17.

Then X_{σ_0} is the affine quadratic cone (cf Example 1.5), X_{σ_1} and X_{σ_2} are affine planes (Example 2.4). The affine quadratic cone is completed by a “circle at infinity” that represents a complex projective line. The real picture of X_{Δ} is a pinched torus.

Example 3.9 Let d_0, \dots, d_n be positive integers. Consider the same fan than in Example 3.4 but consider the lattice N' generated by the vectors $(1/d_i) \cdot v_i$, for $i = 0, \dots, n$. Then the resulting toric variety is

$$\mathbb{P}(d_0, \dots, d_n) = \mathbb{C}^{n+1} - \{0\} / \mathbb{C}^*$$

where \mathbb{C}^* acts on $\mathbb{C}^{n+1} - \{0\}$ by $\zeta \cdot (x_0, \dots, x_n) = (\zeta^{d_0} x_0, \dots, \zeta^{d_n} x_n)$. It is called twisted or weighted projective space.

3.4 Geometric and Topological Properties of Toric varieties

Definition 3.2 A cone σ defined by the set of vectors (v_1, \dots, v_r) is a simplex if all the vectors v_i are linearly independent. A fan Δ is simplicial if all cones of Δ are simplices.

Definition 3.3 A vector $v \in \mathbb{Z}^n$ is primitive if its coordinates are coprime. A cone is regular if the vectors (v_1, \dots, v_r) spanning the cone are primitive and there exists

primitive vectors (v_{r+1}, \dots, v_n) such that $\det(v_1, \dots, v_n) = \pm 1$. In another words, the vectors (v_1, \dots, v_r) can be completed in a basis of the lattice N . A fan is regular if all its cones are regular ones.

Definition 3.4 1. A fan Δ is complete if its cones cover \mathbb{R}^n , i.e. $|\Delta| = \mathbb{R}^n$.
 2. A fan is polytopal if there exists a polytope P such that $0 \in P$ and Δ is spanned by the faces of P (let us recall that a polytope is the convex hull of a finite number of points).

Remark 3.1 1. Every complete fan in \mathbb{R}^2 is polytopal,
 2. Not every complete fan is isomorphic to a polytopal one. For example take the cube in \mathbb{R}^3 with all coordinates ± 1 . The faces of the cube provide a polytopal fan. Now replace the point $(1, 1, 1)$ by $(1, 2, 3)$ and consider the corresponding fan. It is clearly not isomorphic to a polytopal one : there exists 4 vectors generating a face and whose extremities do not lie in the same affine plane.

Theorem 3.2 1. The fan Δ is complete if and only if X_Δ is compact.
 2. The fan Δ is regular if and only if X_Δ is smooth.
 3. The fan Δ is polytopal if and only if X_Δ is projective.

PROOF: Although the results are simple, some of the proofs use deep results of algebraic geometry. We will either give the proofs later as Propositions or will give suitable references for the interested reader.

1.a) If X_Δ is compact, then Δ is complete.

This will be proved in the Proposition 4.3.

1.b) If Δ is complete then X_Δ is compact.

Let us give two references for the proofs of the assertion. The first one ([11], section 2.4) uses properness of the map $X_\Delta \rightarrow \{pt\}$ induced by the morphism of fans $\Delta \rightarrow \{0\}$ (see Remark 2.3 generalized to the case of fans). A properness criteria at the level of valuation rings gives the conclusion.

The second proof, given in [10], VI, theorem 9.1, uses directly considerations on accumulation points in toric varieties.

2.a) If the fan Δ is regular, then X_Δ is smooth.

Example 2.4 shows that if a p -dimensional cone σ is generated by a part of a basis of N , the X_σ is smooth and isomorphic to $\mathbb{C}^p \times (\mathbb{C}^*)^{n-p}$.

2.b) If X_Δ is smooth, then the fan Δ is regular

The proof will be performed in Proposition 4.5

3) The fan Δ is polytopal if and only if X_Δ is projective.

The proof is more delicate, see [10], VII.3. □

The Theorem 3.2 implies the following properties:

Corollary 3.1 (i) An affine toric variety X_σ is smooth if and only if $X_\sigma = \mathbb{C}^p \times (\mathbb{C}^*)^{n-p}$ where $p = \dim \sigma$.

(ii) If Δ is complete, then X_Δ is a compactification of $\mathbb{T} = (\mathbb{C}^*)^n$.

The Lemma 2.2 is generalized in the following way:

Lemma 3.2 Let Δ be a simplicial fan, then X_Δ is an orbifold, i.e. all singularities are quotient singularities.

4 The torus action and the orbits.

4.1 The torus action

The torus $\mathbb{T} = (\mathbb{C}^*)^n$ is a group operating on itself by multiplication. The action of the torus on each affine toric variety X_σ is described as follows :

Let (a_1, \dots, a_k) be a system of generators for the monoid S_σ . With the previous coordinates of \mathbb{R}^n , each a_i is written $a_i = (\alpha_i^1, \dots, \alpha_i^n)$ with $\alpha_i^j \in \mathbb{Z}$ and $t \in \mathbb{T}$ is written $t = (t_1, \dots, t_n)$ with $t_j \in \mathbb{C}^*$. A point $x \in X_\sigma$ is written $x = (x_1, \dots, x_k) \in \mathbb{C}^k$. The action of \mathbb{T} on X_σ is given by :

$$\begin{aligned} \mathbb{T} \times X_\sigma &\rightarrow X_\sigma \\ (t, x) &\mapsto t \cdot x = (t^{a_1} x_1, \dots, t^{a_k} x_k) \end{aligned}$$

where $t^{a_i} = t_1^{\alpha_i^1} \dots t_n^{\alpha_i^n} \in \mathbb{C}^*$.

Example 4.1 In the case of Example 1.5, $a_1 = (1, 0)$, $a_2 = (1, 1)$ and $a_3 = (1, 2)$. For $t \in \mathbb{T}$ we have $t^{a_1} = t_1$, $t^{a_2} = t_1 t_2$ and $t^{a_3} = t_1 t_2^2$. If (x_1, x_2, x_3) is in X_σ , the point $t \cdot x = (t^{a_1} x_1, t^{a_2} x_2, t^{a_3} x_3)$ is also in X_σ .

Now let Δ be a fan in \mathbb{R}^n and let τ be a face of the cone $\sigma \in \Delta$. The identification $X_\tau \cong X_\sigma \setminus (u_k = 0)$ is compatible with the torus action, which implies that the gluing maps $\psi_{\sigma, \sigma'}$ are also compatible with the torus action. We obtain the:

Theorem 4.1 *Let Δ be a fan in \mathbb{R}^n , the torus action on the affine toric varieties X_σ , for $\sigma \in \Delta$, provide a torus action on the toric variety X_Δ .*

4.2 Orbits

Let us consider the case $\Delta = \{0\}$, then $X_\Delta = (\mathbb{C}^*)^n$ is the torus. There is only one orbit which is the total space X_Δ and is the orbit of the point whose coordinates u_i are $(1, \dots, 1)$ in \mathbb{C}^n .

In the general case, the apex $\sigma = \{0\}$ of Δ provides an open dense orbit which is the embedded torus $\mathbb{T} = (\mathbb{C}^*)^n$ (Proposition 3.1). Let us describe the other orbits.

There is a correspondence (see Corollary 2.1)

$$\mathbb{C}^k \leftrightarrow \{\mathcal{M} \subset \mathbb{C}[\xi] : \mathcal{M} \text{ maximal ideal}\} \leftrightarrow \text{Hom}_{\mathbb{C}\text{-alg}}(\mathbb{C}[\xi], \mathbb{C})$$

With this correspondence, the point $x = (x_1, \dots, x_k)$ corresponds to the ideal $\mathcal{M}_x = \mathbb{C}[\xi](\xi_1 - x_1) + \dots + \mathbb{C}[\xi](\xi_k - x_k)$ and to the homomorphism $\varphi : \mathbb{C}[\xi] \rightarrow \mathbb{C}$ such that $\text{Ker}\varphi = \mathcal{M}_x$, i.e. $\varphi(f) = f(x)$.

If I is an ideal in $\mathbb{C}[\xi]$, then $V = V(I) = \{x \in \mathbb{C}^k : I \subset \mathcal{M}_x\}$ and $I_V = I(V(I))$ (Definition 2.4). The set V is an affine algebraic set whose coordinate ring is $R_V = \mathbb{C}[\xi]/I_V$ and we have the correspondence (Corollary 2.2)

$$V \leftrightarrow \{\mathcal{M} \subset R_V : \mathcal{M} \text{ maximal ideal}\} \leftrightarrow \text{Hom}_{\mathbb{C}\text{-alg}}(R_V, \mathbb{C})$$

As a semi-group, the dual lattice M is generated by $\pm e_i^*$, $i = 1, \dots, n$ and the Laurent polynomial ring $\mathbb{C}[M]$ is generated by z_i, z_i^{-1} , $i = 1, \dots, n$. We have identifications

$$\mathbb{T} = \text{Spec}(\mathbb{C}[M]) \cong \text{Hom}(M, \mathbb{C}^*) \cong N \otimes_{\mathbb{Z}} \mathbb{C}^* \cong (\mathbb{C}^*)^n$$

where $N \cong \text{Hom}_{\mathbb{Z}}(M, \mathbb{Z})$ and $\text{Hom}(M, \mathbb{C}^*)$ are group homomorphisms.

All semi-groups $S_\sigma = \check{\sigma} \cap M$ are semi-groups of the lattice M and $\mathbb{C}[S_\sigma]$ is a sub-algebra of $\mathbb{C}[M]$. These sub-algebras are generated by monomials in variables u_i .

If S_σ is generated by (a_1, \dots, a_k) , then elements $u_i = z^{a_i}$, $i = 1, \dots, k$, are generators of the \mathbb{C} -sub-algebra $\mathbb{C}[S_\sigma]$, written as $\mathbb{C}[u_1, \dots, u_k]$. For $a \in S_\sigma$, we will write z^a the corresponding element of $\mathbb{C}[S_\sigma]$, with multiplication $z^a \cdot z^{a'} = z^{a+a'}$ and $z^0 = 1$.

Remark 4.1 Points of $\text{Spec}(\mathbb{C}[S_\sigma])$ correspond to homomorphisms of semi-groups of S_σ in \mathbb{C} where $\mathbb{C} = \mathbb{C}^* \cup \{0\}$ is an abelian semi-group via multiplication:

$$X_\sigma = (\mathbb{C}[S_\sigma]) \cong \text{Hom}_{\text{sg}}(S_\sigma, \mathbb{C})$$

(semi-group homomorphisms). If $\varphi \in \text{Hom}_{\text{sg}}(S_\sigma, \mathbb{C})$, the point x corresponding to φ satisfies $\varphi(a) = z^a(x)$ (evaluation in x) for all $a \in S_\sigma$. This means that $\varphi(a_i)$ is the i -th coordinate of x , i.e. $x = (\varphi(a_1), \dots, \varphi(a_k)) \in \mathbb{C}^k$.

The action of \mathbb{T} on X_σ can be interpreted on the following way:

$$\begin{aligned} t \in \mathbb{T} & \text{ being identified with the group homomorphism } M \xrightarrow{t} \mathbb{C}^* \text{ and} \\ x \in X_\sigma & \text{ being identified with the semi-group homomorphism } S_\sigma \xrightarrow{x} \mathbb{C}, \text{ then} \\ t.x \in X_\sigma & \text{ is identified with the semi-group homomorphism } S_\sigma \rightarrow \mathbb{C}, u \mapsto t(u).x(u) \end{aligned}$$

Definition 4.1 Distinguished points. Let σ be a cone and X_σ the associated affine toric variety. We associate to each face τ of σ a distinguished point x_τ corresponding to the semi-group homomorphism defined, on generators a of S_σ , by

$$\varphi_\tau(a) = \begin{cases} 1 & \text{if } a \in \tau^\perp \\ 0 & \text{in other cases} \end{cases}$$

Example 4.2 In the case of Example 1.5, the generators of S_σ are $a_1 = (1, 0)$, $a_2 = (1, 1)$ and $a_3 = (1, 2)$. If τ_1 is the face generated by $2e_1 - e_2$, then only $a_3 \in \tau_1^\perp$. Then $\varphi_{\tau_1}(a_1) = \varphi_{\tau_1}(a_2) = 0$ and $\varphi_{\tau_1}(a_3) = 1$. The point x_{τ_1} has coordinates $z^{a_1}(x_{\tau_1}) = z^{a_2}(x_{\tau_1}) = 0$ and $z^{a_3}(x_{\tau_1}) = 1$, i.e. $x_{\tau_1} = (0, 0, 1)$.

In the same way, if τ_2 is the face generated by e_2 , then τ_2^\perp is the straight line generated by e_1 . We obtain $\varphi_{\tau_2}(a_1) = 1$ and $\varphi_{\tau_2}(a_2) = \varphi_{\tau_2}(a_3) = 0$. Then $x_{\tau_2} = (1, 0, 0)$.

If we consider σ as a face of σ itself, $\sigma^\perp = \{0\}$, so there is no a_i in σ^\perp and $x_\sigma = (0, 0, 0)$.

Finally if we consider the face $\{0\}$ of σ , then $\{0\}^\perp = \mathbb{R}^2$ contains all points a_i , then $x_{\{0\}} = (1, 1, 1)$.

Definition 4.2 Let σ be a cone in \mathbb{R}^n and τ a face of σ . The orbit of \mathbb{T} in X_σ corresponding to the face τ is the orbit of the distinguished point x_τ , we denote it by O_τ .

Example 4.3 In the previous example,

$$\begin{aligned} O_\sigma &= \{(0, 0, 0)\} \text{ orbit of the distinguished point } x_\sigma = (0, 0, 0) \\ O_{\tau_1} &= \{0\} \times \{0\} \times \mathbb{C}_{\xi_3}^*, \text{ orbit of the distinguished point } x_{\tau_1} = (0, 0, 1) \\ O_{\tau_2} &= \mathbb{C}_{\xi_1}^* \times \{0\} \times \{0\}, \text{ orbit of the distinguished point } x_{\tau_2} = (1, 0, 0) \\ O_{\{0\}} &= (\mathbb{C}^*)^2, \text{ orbit of the distinguished point } x_{\{0\}} = (1, 1, 1) \end{aligned}$$

Fig. 18. Orbits in the quadratic cone.

Theorem 4.2 *Let Δ be a fan in \mathbb{R}^n , for each $\sigma \in \Delta$, we can associate a distinguished point $x_\sigma \in X_\sigma \subset X_\Delta$ and the orbit $O_\sigma \subset X_\sigma$ of x_σ satisfying:*

- 1) $X_\sigma = \coprod_{\tau < \sigma} O_\tau$,
- 2) if V_τ denotes the closure of the orbit O_τ , then $V_\tau = \coprod_{\tau < \sigma} O_\sigma$,
- 3) $O_\tau = V_\tau \setminus \bigcup_{\substack{\tau < \sigma \\ \tau \neq \sigma}} V_\sigma$.

The (easy) proof of the Theorem can be found in [11] 3.1.

Example 4.4 Continuing the example 4.2, $V_{\tau_1} = \overline{O_{\tau_1}}$ is the ξ_3 -axis homeomorphic to \mathbb{C} and is $O_{\tau_1} \coprod O_\sigma = (\mathbb{C}^* \setminus \{0\}) \coprod \{0\}$. One can easily write other relations corresponding to orbits.

Description of the closure V_τ of the orbits

Let τ be a face of the cone σ , then $O_\sigma \subset V_\tau = \overline{O_\tau}$. According to the description of the orbit O_τ , the image of $V_\tau = \overline{O_\tau}$ in a representation of X_σ can be determined in the following way. Let us consider a system of generators (a_1, \dots, a_k) of the monoid S_σ , we denote by I the set of indices $1 \leq i \leq k$ such that $a_i \notin \tau^\perp$. In other words, if (v_1, \dots, v_s) denote the vectors that span τ , one has

$$i \in I \iff \forall j, \quad 1 \leq j \leq s \quad \langle a_i, v_j \rangle \neq 0$$

In X_σ with coordinates $u_i = z^{a_i}$, then V_τ is defined by $u_i = 0$ if $i \in I$.

Let us give two examples :

Example 4.5 In the case of Example 1.5, the affine toric variety X_σ has coordinates $(u_1, u_2, u_3) = (z_1, z_1 z_2, z_1 z_2^2)$ and S_σ is generated by $a_1 = e_1^*$, $a_2 = e_1^* + e_2^*$ and $a_3 = e_1^* + 2e_2^*$. Let us consider the edge τ_1 generated by $2e_1 - e_2$, then

$$i \in I \iff \langle a_i, 2e_1 - e_2 \rangle \neq 0$$

hence $I = \{1, 2\}$. In X_σ , the set V_{τ_1} is defined by $u_1 = 0$, $u_2 = 0$. In $\mathbb{C}_{(\xi_1, \xi_2, \xi_3)}^3$, we have $V_{\tau_1} = \{0\} \times \{0\} \times \mathbb{C}_{\xi_3}$.

Consider the edge τ_2 generated by e_2 , then

$$i \in I \iff \langle a_i, e_2 \rangle \neq 0$$

hence $I = \{2, 3\}$. In X_σ the set V_{τ_2} is defined by $u_2 = 0$, $u_3 = 0$. In $\mathbb{C}^3 = \mathbb{C}_{(\xi_1, \xi_2, \xi_3)}^3$ it is $V_{\tau_2} = \mathbb{C}_{\xi_1} \times \{0\} \times \{0\}$.

The cone σ is a face of itself. For this face, $I = \{1, 2, 3\}$ and, in X_σ , the set V_σ is defined by $u_1 = 0$, $u_2 = 0$, $u_3 = 0$. Hence $V_\sigma = O_\sigma$ is the origin $(0, 0, 0) \in \mathbb{C}^3$.

Example 4.6 Orbits in \mathbb{P}^2 .

With the notations and the pictures of Examples 3.1 and 3.3, let us consider the image of $V_\tau = \overline{O_\tau}$ in X_{σ_0} and X_{σ_1} .

The monoid S_{σ_0} is generated by $a_1 = e_1^*$ and $a_2 = e_2^*$. In X_{σ_0} with coordinates $(u_1, u_2) = (z_1, z_2)$, one has:

$$i \in I \iff \langle a_i, e_2 \rangle \neq 0$$

hence $I = \{2\}$. In $X_{\sigma_0} = \mathbb{C}_{(u_1, u_2)}^2$, V_τ is defined by $u_2 = z_2 = 0$. Hence V_τ is $\mathbb{C}_{\xi_1} \times \{0\}$ and $O_\tau = \mathbb{C}_{z_1}^* \times \{0\}$ is the orbit of $\{x_\tau\} = (1, 0)$. This point is a representation of the point $(1 : 1 : 0)$ of \mathbb{P}^2 .

The monoid S_{σ_1} is generated by $a_1 = -e_1^*$ and $a_2 = -e_1^* + e_2^*$. In X_{σ_1} with coordinates $(u_1, u_2) = (z_1^{-1}, z_1^{-1}z_2)$, one has:

$$i \in I \iff \langle a_i, e_2 \rangle \neq 0$$

hence $I = \{2\}$. In $X_{\sigma_1} = \mathbb{C}_{(u_1, u_2)}^2$, V_τ is defined by $u_2 = z_1^{-1}z_2 = 0$. Hence V_τ is $\mathbb{C}_{(z_1^{-1})} \times \{0\}$. The orbit $O_\tau = \mathbb{C}_{(z_1^{-1})}^* \times \{0\}$ is the same than before, i.e. the orbit of $\{x_\tau\}$.

The projective space is the union of 7 orbits of the torus action :

- $O_{\{0\}} = (\mathbb{C}^*)^2$,
- 3 orbits homeomorphic to \mathbb{C}^* corresponding to the three edges and whose images in each X_{σ_i} are described in the same way than O_τ . They are the orbits of the points $(1 : 1 : 0)$, $(1 : 0 : 1)$ and $(0 : 1 : 1)$ of \mathbb{P}^2 .
- 3 fixed points $\{x_{\sigma_i}\}$, $i = 1, 2, 3$ corresponding to the 2-dimensional cones σ_i . They are fixed points of the torus action and are the points $(1 : 0 : 0)$, $(0 : 1 : 0)$ and $(0 : 0 : 1)$.

Example 4.7 Let us consider the cone $\sigma \in \mathbb{R}^n$ generated by all vectors e_i of the basis of \mathbb{R}^n and the face τ generated by $(e_i)_{i \in I}$ with $I \subset \{1, \dots, n\}$, $|I| = p$. The orbit O_τ containing x_τ is

$$\{(z_1, \dots, z_n) \in \mathbb{C}^n : z_i = 0 \text{ for } i \in I, \text{ and } z_i \neq 0 \text{ for } i \notin I\}$$

Then $O_\tau \cong \text{Hom}(\tau^\perp \cap M, \mathbb{C}^*)$. If $\dim \tau = p$, then $\dim \tau^\perp = n - p$ and $\dim_{\mathbb{C}} O_\tau = n - p$.

Abstract description of orbits O_τ and their closure V_τ .

Let us fix τ and denote by N_τ the sublattice of N generated (as a group) by $\tau \cap N$,

$$(SL) \quad N_\tau = (\tau \cap N) + (-\tau \cap N).$$

As τ is saturated (i.e. if $n.u \in \tau$ for $n \in \mathbb{Z}_{\geq 0}$, then $u \in \tau$), then N_τ is also saturated. The quotient $N(\tau) = N/N_\tau$ is also a lattice, called the quotient lattice. Its dual lattice is $M(\tau) = \tau^\perp \cap M$.

Then $O_\tau = \mathbb{T}_{N(\tau)} = \text{Hom}(M(\tau), \mathbb{C}^*) = \text{Spec}(\mathbb{C}[M(\tau)])$ is a torus whose dimension is $n - \dim(\tau)$. The torus \mathbb{T}_N acts on O_τ transitively, via the projection $\mathbb{T}_N \rightarrow \mathbb{T}_{N(\tau)}$.

Let us denote by $N_{\mathbb{R}} = N \otimes_{\mathbb{Z}} \mathbb{R}$ the real vector space associated to N . For each cone σ such that $\tau < \sigma$, one defines the ‘‘quotient cone’’

$$\bar{\sigma} = (\sigma + (N_\tau)_{\mathbb{R}}) / (N_\tau)_{\mathbb{R}} \subset N_{\mathbb{R}} / (N_\tau)_{\mathbb{R}} = N(\tau)_{\mathbb{R}}$$

Definition 4.3 The star of τ is defined by

$$\text{Star}(\tau) = \{\bar{\sigma} : \tau < \sigma\}$$

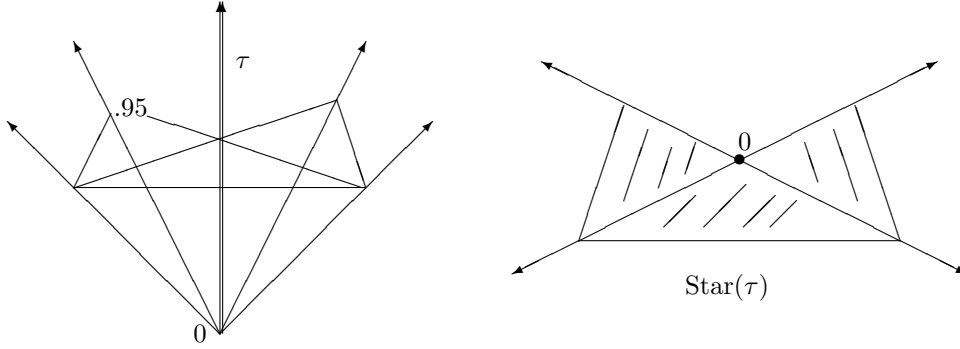

Fig. 19. Star of τ

The closure of O_τ is identified to $V(\tau) = X_{Star(\tau)}$. It is a toric variety whose dimension is $n - \dim(\tau)$. The embedding of the torus O_τ in $V(\tau)$ corresponds to the cone $\{0\} = \bar{\tau}$ in $N(\tau)$.

- Property 4.1**
1. If $\dim_{\mathbb{R}} \sigma = n$, then O_σ is a fixed point $\{x_\sigma\}$. Consider a representation of X_σ in \mathbb{C}^k , then $O_\sigma = \{x_\sigma\}$ corresponds to the origin of \mathbb{C}^k .
 2. If $\dim_{\mathbb{R}} \sigma = k$, then $O_\sigma \cong (\mathbb{C}^*)^{n-k}$.
 3. Let τ_i be an edge (1-dimensional cone) in Δ , then $O_{\tau_i} \cong (\mathbb{C}^*)^{n-1}$. If $\dim_{\mathbb{R}} \Delta = n$, then $D_i = V_{\tau_i}$ is a codimension one variety in X_Δ . We will see that D_i is a Weil divisor.

Let $\tau < \sigma$, then the toric variety $V(\tau)$ is covered by the following affine varieties $U_\sigma(\tau)$ (see [11]3.1):

$$U_\sigma(\tau) = \text{Spec}(\mathbb{C}[(\check{\sigma}) \cap M(\tau)]) = \text{Spec}(\mathbb{C}[\check{\sigma} \cap \tau^\perp \cap M]).$$

Let us remark that $\check{\sigma} \cap \tau^\perp$ is the face of $\check{\sigma}$ corresponding to τ by duality. In particular $U_\tau(\tau) = O_\tau$.

4.3 Toric varieties and fans

We have seen the process which associates a toric variety to a fan. In this section, one is interested by the converse question: can we associate a fan to a “suitable” variety?

For each $k \in \mathbb{Z}$, one has an algebraic groups homomorphism

$$\mathbb{C}^* \rightarrow \mathbb{C}^* \quad z \mapsto z^k$$

providing the isomorphism $\text{Hom}_{alg. gr.}(\mathbb{C}^*, \mathbb{C}^*) = \mathbb{Z}$.

Let N be a lattice, with dual lattice M , one has

$$(A) \quad \mathbb{T} = \mathbb{T}_N = \text{Hom}(M, \mathbb{C}^*)$$

and, with the choice of a basis for N , one has isomorphisms

$$(B) \quad \text{Hom}(\mathbb{C}^*, \mathbb{T}) \cong \text{Hom}(\mathbb{Z}, N) \cong N.$$

Every one-parameter sub-group $\lambda : \mathbb{C}^* \rightarrow \mathbb{T}$ corresponds to an unique $v \in N$. Let us denote by λ_v the one-parameter sub-group corresponding to v . One has

$$v = (v_1, \dots, v_n) \in \mathbb{Z}^n \quad \lambda_v(z) = (z^{v_1}, \dots, z^{v_n})$$

In a dual way, one has: $\text{Hom}(\mathbb{T}, \mathbb{C}^*) \cong \text{Hom}(N, \mathbb{Z}) \cong M$.

Every character $\chi : \mathbb{T} \rightarrow \mathbb{C}^*$ corresponds to an unique $u \in M$. Let $\chi^u \in \text{Hom}(\mathbb{T}, \mathbb{C}^*)$ be the character corresponding to $u = (u_1, \dots, u_n) \in M$. For $t = (t_1, \dots, t_n) \in \mathbb{T}$, then $\chi^u(t) = t_1^{u_1} \dots t_n^{u_n}$. We will denote also by χ^u the corresponding function in the coordinate ring $\mathbb{C}[M]$.

[Let us recall that a basis of the complex vectorial space $\mathbb{C}[M]$ is given by the elements χ^u with $u \in M$. To the generators $u_i \in M$ correspond generators χ^{u_i} for the \mathbb{C} -algebra $\mathbb{C}[M]$. More precisely, if (e_1, \dots, e_n) is a basis for N , (e_1^*, \dots, e_n^*) is a basis for M and $\chi^{e_i^*} = \chi_i$ a basis for the ring of Laurent polynomial with n variables $\mathbb{C}[M]$.]

If $z \in \mathbb{C}^*$, then $\lambda_v(z) \in \mathbb{T}$, and (by (A)), $\lambda_v(z)$ corresponds to a group homomorphism from M in \mathbb{C}^* . More explicitly

$$\lambda_v(z)(u) = \chi^u(\lambda_v(z)) = z^{\langle u, v \rangle}$$

where $\langle \cdot, \cdot \rangle$ is the dual pairing $M \otimes N \rightarrow \mathbb{Z}$, i.e.

$$\begin{array}{ccc} u & v & \mapsto \langle u, v \rangle \\ M & \times & N & \longrightarrow & \mathbb{Z} \\ \text{Hom}(\mathbb{T}, \mathbb{C}^*) \times \text{Hom}(\mathbb{C}^*, \mathbb{T}) & \longrightarrow & \text{Hom}(\mathbb{C}^*, \mathbb{C}^*) \\ \chi & \lambda & \mapsto z \mapsto z^{\langle u, v \rangle} = \chi^u(\lambda_v(z)) \end{array}$$

In fact, it $t = \lambda_v(z)$ with $v = (v_1, \dots, v_n) \in N = \mathbb{Z}^n$ and $z \in \mathbb{C}^*$, then $t_i = z^{v_i}$ and

$$\chi^u(\lambda_v(z)) = \chi^u(t) = t_1^{u_1} \dots t_n^{u_n} = (z^{v_1})^{u_1} \dots (z^{v_n})^{u_n} = z^{u_1 v_1 + \dots + u_n v_n} = z^{\langle u, v \rangle}$$

By this description, one recovers the lattice N from $\mathbb{T} = \mathbb{T}_N$.

Conversely, can we recover the cone σ from the embedding $\mathbb{T} \hookrightarrow X_\sigma$? For this purpose, we look at the behavior of the limit $\lim_{z \rightarrow 0} \lambda_v(z)$ for v (varying) in N .

For example, let us suppose that σ is the cone generated by a part (e_1, \dots, e_p) of a basis for N . We know that $X_\sigma = \mathbb{C}^p \times (\mathbb{C}^*)^{n-p}$ (Example 2.7). For $v = (v_1, \dots, v_n) \in \mathbb{Z}^n$, then $\lambda_v(z) = (z^{v_1}, \dots, z^{v_n})$ and the limit $\lim_{z \rightarrow 0} \lambda_v(z)$ exists and lies in X_σ if and only if $v_i \geq 0$ for all v_i and $v_i = 0$ if $i > p$. In other words, the limit exists in X_σ if and only if $v \in \sigma$ and in that case, the limit is (y_1, \dots, y_n) where $y_i = 1$ if $v_i = 0$ and $y_i = 0$ if $v_i > 0$. The possible limits are the distinguished points x_τ for $\tau < \sigma$.

Let us remark that the point x_τ is independent of σ such that τ is a face of σ . If $\tau < \sigma < \gamma$, the inclusion $X_\sigma \hookrightarrow X_\gamma$ sends the point x_τ of X_σ on the point x_τ of X_γ .

Proposition 4.1 *If $v \in |\Delta|$ and τ is the cone of Δ containing v in its relative interior, then $\lim_{z \rightarrow 0} \lambda_v(z) = x_\tau$.*

PROOF: We work in X_σ for all σ containing τ as a face. We know that $\lambda_v(z)$ is identified with the homomorphism from M to \mathbb{C}^* , $u \mapsto z^{\langle u, v \rangle}$. As v is in the relative interior of τ and $\tau < \sigma$, for $u \in S_\sigma = \check{\sigma} \cap M$, one has $\langle u, v \rangle \geq 0$ and equality holds exactly for elements $u \in \tau^\perp$. Let us remember that x_τ corresponds to the semi-group homomorphism $S_\sigma \rightarrow \mathbb{C}$ which sends u on 1 if $u \in \tau^\perp$ and on 0 in other cases. The limit homomorphism from S_σ to \mathbb{C} is the one which defines x_τ . \square

Proposition 4.2 *If v does not belong to any cone of Δ , then $\lim_{z \rightarrow 0} \lambda_v(z)$ does not exist in X_Δ .*

PROOF: If $v \notin \sigma$, the points $\lambda_v(z)$ have no limit in X_σ when z goes to 0. To see that, take $u \in \check{\sigma}$ such that $\langle u, v \rangle < 0$ (we have $\sigma = (\check{\sigma})$), then $\chi^u(\lambda_v(z)) = z^{\langle u, v \rangle}$ goes to infinite when z goes to 0. \square

As a conclusion, $\sigma \cap N$ is the set of vectors $v \in N$ such that $\lambda_v(z)$ admits a limit in X_σ when z goes to 0 and the limit is x_σ if v is in the relative interior of σ . If v does not belong to $|\Delta|$ (union of the cones of Δ), then the limit does not exist.

Proposition 4.3 *If X_Δ is compact, then Δ is complete.*

PROOF: If $|\Delta|$ is not all $N_{\mathbb{R}}$, there would be a vector v such that v does not belong to any cone (Δ is finite). In that case, $\lambda_v(z)$ does not have a limit in X_Δ when z goes to 0 and that gives a contradiction with the compactity. \square

Exercises : 1. For $v \in N$, the morphism $\lambda_v : \mathbb{C}^* \rightarrow \mathbb{T}$ extends in a morphism $\mathbb{C} \rightarrow X_\Delta$ if and only if $v \in |\Delta|$.

2. For $v \in N$, the morphism λ_v extends in a morphism $\mathbb{P}^1 \rightarrow X_\Delta$ if and only if v and $-v$ belong to $|\Delta|$.

Proposition 4.4 *Toric varieties are normal.*

PROOF: An algebraic variety is normal if, for any point x , the local ring R_x is integrally closed. For a toric variety, the local ring in x_σ is R_σ . If σ is generated by (v_1, \dots, v_r) , the Lemma 1.1 implies that $R_\sigma = \cap R_{\tau_i}$ where the τ_i are the rays corresponding to the vectors v_i . As $R_{\tau_i} \cong \mathbb{C}[x_1, x_2, x_2^{-1}, \dots, x_n, x_n^{-1}]$ is integrally closed and the intersection of integrally closed domains is integrally closed, we obtain the result. \square

From the previous result, one obtains the following ‘‘Second Definition of Toric Varieties’’:

Theorem 4.3 *A (n -dimensional) toric variety is an algebraic normal variety X that contains a torus $\mathbb{T} \cong (\mathbb{C}^*)^n$ as a dense open subset, together with an action $\mathbb{T} \times X \rightarrow X$ of \mathbb{T} on X that extends the natural action of the torus \mathbb{T} on itself.*

or, equivalently:

Theorem 4.4 *A (n -dimensional) toric variety is an algebraic normal variety X with an algebraic action of the torus $\mathbb{T} \cong (\mathbb{C}^*)^n$, which is almost transitive and effective.*

The almost transitive action implies the existence of a dense orbit and effectiveness implies that the dense orbit is a torus.

Proposition 4.5 *If the toric variety X_Δ associated to a fan Δ is smooth, then the fan Δ is regular.*

PROOF: Let us consider firstly the case of the fan generated by a cone σ such that $\dim(\sigma) = n$. Then if $S_\sigma = \check{\sigma} \cap M$ is generated by (a_1, \dots, a_k) , one has

$$\mathbb{C}[S_\sigma] = R_\sigma = \mathbb{C}[z^{a_1}, \dots, z^{a_k}] = \mathbb{C}[\xi_1, \dots, \xi_k]/I,$$

local ring of x_σ .

Let us denote by \mathcal{M} the maximal ideal of A_σ corresponding to the point x_σ . Then

$$X_\sigma \text{ is smooth} \iff R_\sigma \text{ is regular} \xLeftrightarrow{\text{def}} \dim R_\sigma = \dim_k \mathcal{M}/\mathcal{M}^2$$

where $\mathcal{M}/\mathcal{M}^2$ is identified with the cotangent space.

As $\dim R_\sigma = \dim X_\sigma = \dim \mathbb{T} = n$, one obtains:

$$X_\sigma \text{ is smooth} \iff \dim_k \mathcal{M}/\mathcal{M}^2 = n$$

\mathcal{M} is generated by all elements χ^u for $u \neq 0$ in S_σ and \mathcal{M}^2 is generated by all elements χ^u such that u is sum of two elements of $S_\sigma - \{0\}$.

$\mathcal{M}/\mathcal{M}^2$ has for basis the images of elements χ^u for $u \in S_\sigma - \{0\}$ which are not sum of two vectors in $S_\sigma - \{0\}$. In particular, the first elements in M on the rays of $\tilde{\sigma}$ (primitive vectors) are elements of $\mathcal{M}/\mathcal{M}^2$.

If X_σ is smooth, $\tilde{\sigma}$ cannot have more than n rays and the primitive generators of these rays must generate S_σ .

As σ is strongly convex, $\tilde{\sigma}$ generates $M_{\mathbb{R}}$ and S_σ generates M as a group (i.e. $M = S_\sigma + (-S_\sigma)$). The primitive generators of S_σ give a basis of M and, by duality, σ is generated by a basis of N . This implies $X_\sigma \cong \mathbb{C}^n$.

Let us now consider the general case, i.e. $\dim \sigma = p \leq n$.

In that case, let us consider the sub-lattice $N_\sigma = (\sigma \cap N) + (-\sigma \cap N) \subset N$ generated (as a sub-group) by $\sigma \cap N$ (see (SL)).

One has a decomposition $N = N_\sigma \oplus N''$, such that $\sigma = \sigma' \oplus \{0\}$, and the cone σ' , in N_σ , satisfies $\dim \sigma' = \dim \sigma = \dim N_\sigma$.

Using the dual decomposition $M = M' \oplus M''$, one has

$$S_\sigma = ((\sigma') \cap M') \oplus M'' \text{ and}$$

$$X_\sigma = X_{\sigma'} \times \mathbb{T}_{N''} \cong X_{\sigma'} \times (\mathbb{C}^*)^{n-p}$$

and $X_{\sigma'}$ is the toric variety corresponding to the cone σ' in the lattice N_σ (respectively to the torus \mathbb{T}_{N_σ}).

If X_σ is smooth, then $X_{\sigma'}$ must be smooth and σ' must be a basis for N_σ . \square

4.4 Toric variety associated to a polytope

Let P be a convex polytope in $(\mathbb{R}^n)^*$, i.e. the convex hull of a finite number of points. We associate the polar polytope P° in \mathbb{R}^n in the following way:

$$P^\circ = \{v \in \mathbb{R}^n : \langle u, v \rangle \geq -1, \quad \forall u \in P\}$$

Lemma 4.1 a) P° is a convex polytope.

b) if P is rational (lattice polytope), then P° is a lattice polytope.

A face F of P is written

$$F = \{u \in P : \langle u, v \rangle = r \text{ where } v \in \mathbb{R}^n \text{ is such that } \langle u, v \rangle \geq r, \forall u \in P\}$$

In the following we suppose that $\{0\} \in \text{Int}(P)$. For every face F of P then

$$F^* = \{v \in P^\circ : \langle u, v \rangle = -1, \forall u \in F\} \text{ is a face of } P^\circ.$$

Example 4.8 1. The polar polytope of

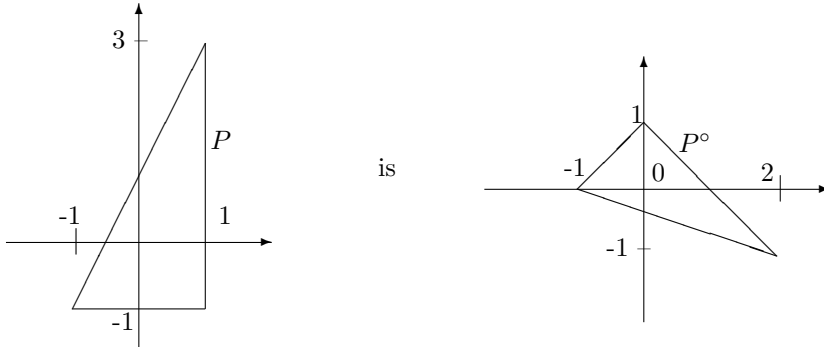
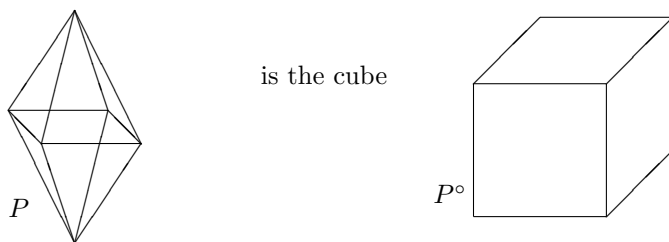

Fig. 20.

2. The polar polytope of the octaedrum (whose all vertices have coordinates 0 or ± 1)



whose all vertices have coordinates ± 1 .

Fig. 21.

Lemma 4.2 a) *There is a one-to-one correspondence between faces of P and faces of $P^\circ : F \leftrightarrow F^*$ reversing order.*

b) $\dim F + \dim F^* = n - 1$.

Fan associated to a polytope. Let P a polytope, we associate a cone σ_F to each face F of the polytope P in the following way:

$$\sigma_F = \{v \in N_{\mathbb{R}} : \langle u, v \rangle \leq \langle u', v \rangle \quad \forall u \in F, \forall u' \in P\}$$

The dual cone $\check{\sigma}_F$ in $(\mathbb{R}^n)^*$ is generated by the vectors $u' - u$ such that $u \in F, u' \in P$. The cone σ_F , in \mathbb{R}^n , has F^* for basis.

Example 4.9

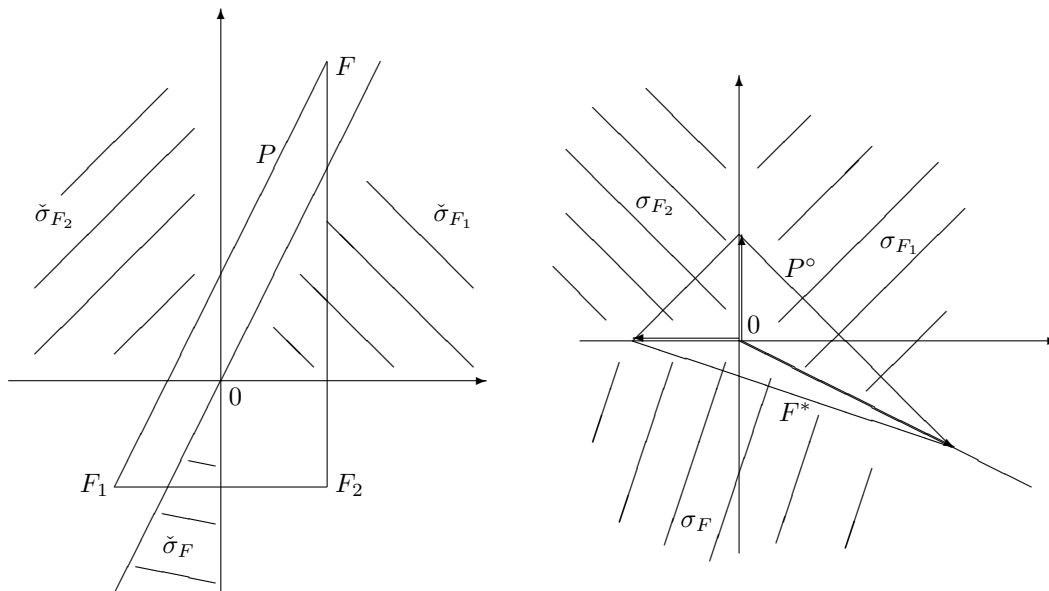

Fig. 22.

In this picture, the polar polytope of P is P° . To the face F of P (here a vertex), we associate the face F^* of P° , the cone σ_F in \mathbb{R}^n and its dual $\check{\sigma}_F$ in $(\mathbb{R}^n)^*$.

Proposition 4.6 a) *The cones σ_F form a fan Δ_P .*

b) *If $\{0\} \in \text{Int}(P)$, then Δ_P is made of the cones based on the faces of the polar polytope P° .*

The proof of the Proposition is an easy exercise (see [11], 1.5).

Definition 4.4 *A function $\psi : |\Delta| \rightarrow \mathbb{R}$ is called support function on Δ if it takes integer values on $N \cap |\Delta|$, is linear on each cone $\sigma \in \Delta$ and is positively homogeneous (i.e. $\psi(\alpha v) = \alpha\psi(v)$ for $v \in |\Delta|$ and $\alpha > 0$).*

If P denotes a n -convex polytope whose vertices are in M , we define the support function associated to P as

$$\psi_P : N_{\mathbb{R}} \rightarrow \mathbb{R} \quad \psi_P(v) = \inf_{u \in P} \langle u, v \rangle$$

The support function ψ_P has integer values on N . Conversely, the polytope P is defined by the support function ψ_P in the following way:

$$P = \{u \in M_{\mathbb{R}} : \langle u, v \rangle \geq \psi_P(v) \quad \forall v \in N_{\mathbb{R}}\}$$

Let us consider the (finite) complete fan Δ_P associated to P . Then $\psi_P \in SP(\Delta_P)$ and ψ_P is strictly upper convex relatively to Δ_P , i.e. for all $\sigma \in \Delta_P$, there is $u_{\sigma} \in M$ such that

$$\psi_P(v) \leq \langle u_{\sigma}, v \rangle \quad \forall v \in |\Delta|$$

and there is equality if and only if $v \in \sigma$.

We recover the correspondence between faces F of P and cones σ of Δ . The cone σ_F is defined by

$$\sigma_F = \{v \in N_{\mathbb{R}} : \psi(v) = \langle u, v \rangle \quad \forall u \in F^{\circ}\}$$

The fan Δ_P is polytopal, i.e. is generated by the faces of a polytope. Let us remark that, by Theorem 3.2, the toric variety X_{Δ_P} is a projective variety.

More relations between polytopes and fans will be given in 5.2.

5 Divisors and homology

5.1 Divisors

Let us consider firstly the case of a general complex algebraic variety X .

Definition 5.1 A Weil divisor is an element of the free abelian group $W(X)$ generated by the irreducible closed subvarieties of (complex) codimension 1 in X .

Such a divisor can be written :

$$\sum n_i A_i - \sum m_j B_j \quad \text{with } n_i, m_j > 0$$

where the A_i and B_j are subvarieties of codimension 1 in X .

Example 5.1 In the space \mathbb{C}^2 with coordinates (z_1, z_2) , let us consider the axis $z_1 = 0$ denoted by A , and the axis $z_2 = 0$ denoted by B . An example of Weil divisor is given by $2A - B$.

Let us denote by $\mathcal{R}(U)$ the set of rational functions in an affine open set U in X .

Definition 5.2 A Cartier divisor (or locally principal divisor) $D = (U_\alpha, f_\alpha)$ is the data of a covering $X = \bigcup U_\alpha$ of X by affine open sets and nonzero rational functions $f_\alpha \in \mathcal{R}(U_\alpha)$. These data must satisfy the following property: if $U_\alpha \cap U_\beta \neq \emptyset$, then $f_\alpha/f_\beta \in \mathcal{O}^*(U_\alpha \cap U_\beta)$ (nowhere zero holomorphic function). The set of Cartier divisors is a group denoted by $C(X)$.

Example 5.2 Let us consider $X = \mathbb{C}^2$ covered by only one open set $U = \mathbb{C}^2$ and consider, in U , the rational function $f(z_1, z_2) = z_1^2/z_2$, we obtain a Cartier divisor $D = (U, f)$.

Proposition 5.1 Let X be a normal variety, there is an inclusion

$$C(X) \hookrightarrow W(X)$$

Example 5.3 Let us explicit this inclusion in the previous example : If $A = \{f = 0\}$ is the set of zeroes of f counted with multiplicities and $B = \{1/f = 0\}$ is the set of poles of f counted with multiplicities, then the previous Weil divisor $2A - B$ corresponds to the previous Cartier divisor $D = (U, f)$.

In general the map $C(X) \rightarrow W(X)$ is defined by

$$D \mapsto [D] = \sum_{\text{codim}(V,X)=1} \text{ord}_V(D) \cdot V$$

where $\text{ord}_V(D)$ is the vanishing order of an equation for D in the local ring along the subvariety V . If X is normal, then local rings are discrete valuation rings and the order is the naive one.

In fact, the previous example is an example of *principal divisor* : The subgroup of principal divisors, denoted by $P(X)$, is the subgroup of Cartier divisors corresponding to the nonzero rational functions. Let us consider the quotients :

$$\mathcal{C}(X) = C(X)/P(X) \quad \text{and} \quad \mathcal{W}(X) = W(X)/P(X)$$

There is an inclusion $\mathcal{C}(X) \hookrightarrow \mathcal{W}(X)$, which is not an equality as shown by the example of the toric variety of Example 2.8 (with $q=1$) : let X be the quotient variety of \mathbb{C}^2 by the subgroup G of p -th roots of unity. Then, we have :

$$\mathcal{C}(X) = \{0\} \hookrightarrow \mathcal{W}(X) = \mathbb{Z}_p .$$

Let $X = X_\Delta$ be a toric variety. The Weil and Cartier divisor classes, invariant by the action of the torus \mathbb{T} will be denoted respectively $C^\mathbb{T}(X)$ and $W^\mathbb{T}(X)$. In the same way, the subgroup of the invariant principal divisors will be denoted $P^\mathbb{T}(X)$. We define $\mathcal{C}^\mathbb{T}(X) = C^\mathbb{T}(X)/P^\mathbb{T}(X)$ et $\mathcal{W}^\mathbb{T}(X) = W^\mathbb{T}(X)/P^\mathbb{T}(X)$. There is still an inclusion

$$\mathcal{C}^\mathbb{T}(X) \hookrightarrow \mathcal{W}^\mathbb{T}(X)$$

Let Δ be a fan containing q edges and let X_Δ be the associated toric variety. Let τ_i be a edge of Δ and denote by $D_i = V_{\tau_i}$ the closure of the orbit O_{τ_i} associated to τ_i , then D_i is an invariant Weil divisor and all such divisors are on the form

$$\sum_{i=1}^q \lambda_i D_i \quad \lambda_i \in \mathbb{Z} .$$

We obtain :

Lemma 5.1 *The group of invariant Weil divisors is homeomorphic to :*

$$W^\mathbb{T}(X) \cong \bigoplus_{i=1}^q \mathbb{Z}[D_i]$$

There is a surjective homomorphism

$$\begin{aligned} \text{div} : M &\rightarrow C^\mathbb{T}(X) \\ u &\mapsto \text{div}(u) = \sum_{i=1}^q \langle u, v_i \rangle D_i \end{aligned}$$

where v_i is the first lattice point on the edge τ_i . This implies :

Lemma 5.2 *Let $u \in M$ and v_i the first lattice point of the edge τ_i , then*

$$\text{ord}_{V_{\tau_i}}(\text{div}(u)) = \langle u, v_i \rangle$$

Let us consider a cone σ , an invariant Cartier divisor on X_σ is written $\text{div}(u)$ for some $u \in M$. Moreover,

$$\text{div}(u) = \text{div}(u') \Leftrightarrow u - u' \in \sigma^\perp \cap M = M(\sigma)$$

and one obtains

$$C^\mathbb{T}(X_\sigma) \cong M/M(\sigma).$$

In general, Cartier invariant divisors on X_Δ are defined by data $u(\sigma) \in M/M(\sigma)$ for all σ , providing divisors $\text{div}(-u(\sigma))$ on X_σ and which coincide on intersections. It means that if $\tau < \sigma$, the image of $u(\sigma)$ by the canonical map $M/M(\sigma) \rightarrow M/M(\tau)$ is $u(\tau)$. One obtains

$$C^\mathbb{T}(X_\Delta) = \text{Ker} \left[\bigoplus_i M/M(\sigma_i) \rightarrow \bigoplus_{i < j} M/M(\sigma_i \cap \sigma_j) \right].$$

Proposition 5.2 *A Weil divisor $\sum a_i D_i$ is a Cartier divisor if and only if for every maximal cone σ there is $u(\sigma) \in M$ such that for all $v_i \in \sigma$ one has $\langle u(\sigma), v_i \rangle = a_i$.*

Example 5.4 In the case of Example 1.5, there are two invariant Weil divisors corresponding to the two edges of the cone σ : D_1 corresponding to the edge τ_1 of e_2 and D_2 corresponding to the edge τ_2 spanned by $2e_1 - e_2$. If $u \in M$ has coordinates (a, b) in $(\mathbb{C}^*)^2$, then $\text{div}(u) = bD_1 + (2a - b)D_2$ and all invariant Cartier divisors are on this form. For example, $2D_1$ and $2D_2$ are such Cartier divisors but D_1 and D_2 are not.

The two divisors $2D_1$ and $2D_2$ are principal divisors, so we obtain : $\mathcal{C}^\mathbb{T}(X) = 0$ and $W^\mathbb{T}(X) = \mathbb{Z}_2$.

Example 5.5 The Weil divisor $D_1 + D_2 + D_3$ of Example 3.8 is a Cartier divisor, D_1 is not a Cartier divisor.

Example 5.6 Let σ be the cone spanned by $x_1 = 2e_1 - e_2$ and $x_2 = -e_1 + 2e_2$. Each of these two vectors span an edge τ_i and the two corresponding Weil divisors are denoted D_1 and D_2 . Then $\lambda_1 D_1 + \lambda_2 D_2$ is a Cartier divisor if and only if $\lambda_1 = \lambda_2 \pmod{3}$ (Exercise).

5.2 Support functions and divisors.

The set of support functions (Definition 4.4) is a \mathbb{Z} -module denoted by $SF(\Delta)$. An element u of M can be viewed as a support function and one has an inclusion of \mathbb{Z} -modules:

$$\text{Hom}(N, \mathbb{Z}) = M \subset SF(\Delta)$$

Support functions are also called piecewise linear characters. The reason is that one can write $SF(\Delta)$ in the following way

$$SF(\Delta) = \{h : N \rightarrow \mathbb{Z} : \forall \sigma \in \Delta^{(n)} \quad \exists u_\sigma \in M \quad h|_{\sigma \cap M} = u_\sigma|_{\sigma \cap M}\}$$

Let (v_1, \dots, v_q) be the primitive vectors of the edges τ_i of Δ , one defines a map

$$SF(\Delta) \hookrightarrow W^\mathbb{T}(X_\Delta) \quad \psi \mapsto \text{div}(\psi) = \sum_{i=1}^q \psi(v_i) D_i$$

where D_i is the Weil divisor corresponding to τ_i . Let us remark that $\text{div}(\psi)$ is an invariant Cartier divisor.

Lemma 5.3 *There is an isomorphism*

$$SF(\Delta) \cong \mathcal{C}^\mathbb{T}(X_\Delta)$$

and in the non degenerate case

$$SF(\Delta)/M \cong \mathcal{C}^\mathbb{T}(X_\Delta)$$

Let us consider a polytope P and the associated support function $\psi_P \in SF(\Delta_P)$. The Cartier divisor $D_P = \sum \psi_P(v_i) D_i$ corresponding to ψ_P is ample, this property is equivalent to the fact that ψ_P is strictly upper convex, i.e.

$$\psi(v) + \psi(v') \leq \psi(v + v')$$

Theorem 5.1 *There is a bijective correspondence between*

$$\left(\begin{array}{l} \text{integer } n\text{-dimens}^{\text{al}} \\ \text{polytopes } P \text{ in } M_{\mathbb{R}} \end{array} \right) \leftrightarrow \left(\begin{array}{l} \text{pairs } (\Delta, \psi) \text{ with} \\ \Delta \text{ finite, complete,} \\ \psi \in SF(\Delta) \text{ strictly} \\ \text{upper convex rel}^t \text{ to } \Delta \end{array} \right) \leftrightarrow \left(\begin{array}{l} \text{pairs } (X, D) \text{ with} \\ X \text{ projective variety} \\ D \text{ ample Cartier div.} \end{array} \right)$$

If moreover P is simple (i.e. every vertex is incident to n rays) then Δ is simplicial if and only if X is an orbifold.

5.3 Divisors, homology and cohomology.

Let us come back to the general case of a complex algebraic variety. For more details on this section, see [11], 3.3. These results will be used in section 7.1.

Let n denote the (complex) dimension of X . A Weil divisor defines an $(2n - 2)$ -cycle in X . The application which associates, to each Weil divisor, its homology class defines in an evident way an homomorphism $\kappa : W(X) \rightarrow H_{2n-2}(X)$. The image of a principal divisor is zero, so we obtain an homomorphism, still denoted

$$\kappa : \mathcal{W}(X) \rightarrow H_{2n-2}(X).$$

In other hand, for a normal variety, there is an isomorphism (cf. [12], II, Prop. 6.15)

$$\varphi : \mathcal{C}(X) \xrightarrow{\cong} \text{Pic}(X)$$

between the group of classes of Cartier divisors and the Picard group of X , denoted $\text{Pic}(X)$. This one is the group of isomorphy classes of line bundles (or isomorphy classes of invertible sheaves) on X . The isomorphism φ is given by the map which associates, to the divisor $D = (U_{\alpha}, f_{\alpha})$, the subsheaf $\mathcal{O}(D)$ of the sheaf of rational functions, generated by $1/f_{\alpha}$ on U_{α} . The sheaf $\mathcal{O}(D)$ corresponds to the line bundle whose transition functions $U_{\alpha} \rightarrow U_{\beta}$ are given by f_{α}/f_{β} . Reciprocally, given an invertible sheaf, we associate the class of the divisor of a global rational and non trivial section.

Note that the kernel of φ is the group of principal divisors on X .

The data $\{u(\sigma) \in M/M(\sigma)\}$ for a Cartier divisor D determines a continuous piecewise function ψ_D on the support $|\Delta|$. The restriction of ψ_D to the cone σ is the linear function $u(\sigma)$:

$$\psi_D(v) = \langle u(\sigma), v \rangle \quad \text{for } v \in \sigma.$$

If $D = \sum a_i D_i$, then $\psi_D(v_i) = -a_i$ (see 5.2).

An invariant Cartier divisor $D = \sum a_i D_i$ on X_{Δ} determines a rational convex polyhedron in $M_{\mathbb{R}}$ by

$$P_D = \{u \in M_{\mathbb{R}} : \langle u, v_i \rangle \geq -a_i \quad \forall i\}$$

and the global sections of the line bundle $\mathcal{O}(D)$ are given by

$$\Gamma(X, \mathcal{O}(D)) = \bigoplus_{u \in P_D \cap M} \mathbb{C} \cdot \chi^u.$$

By composition of φ with the morphism $\text{Pic}(X) \rightarrow H^2(X)$, which associates to each line bundle ξ on X its Chern class $c^1(\xi)$, we obtain a morphism denoted

$$c^1 : \mathcal{C}(X) \rightarrow H^2(X).$$

Proposition 5.3 *For toric varieties there is an isomorphism*

$$\mathcal{C}^{\mathbb{T}}(X) \cong \text{Pic}(X), \quad D \mapsto \mathcal{O}(D)$$

6 Resolution of singularities

6.1 The Hirzebruch surface

Let us consider the fan consisting of the cones σ_0 and σ_1 and their faces in the following picture:

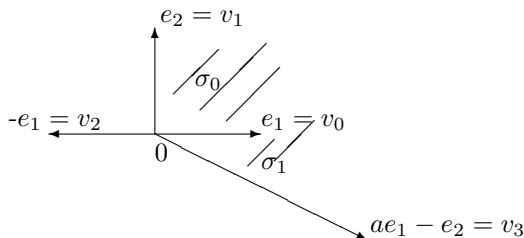

Fig. 23.

Then X_{σ_0} and X_{σ_1} are smooth. Writing x the coordinate corresponding to e_1^* and y the one corresponding to e_2^* , one obtains (Example 3.7)

$$X_{\sigma_0} = \mathbb{C}_{(x,y)} \quad \text{and} \quad X_{\sigma_1} = \mathbb{C}_{(xy^a, y^{-1})}$$

The common ray $\tau = \sigma_0 \cap \sigma_1$ determines a curve D_τ on the surface X , contained in the union of the open subsets X_{σ_0} and X_{σ_1} . We show that $D_\tau \cap X_{\sigma_0}$ is \mathbb{C} , also $D_\tau \cap X_{\sigma_1}$ is \mathbb{C} and the union of both is \mathbb{P}^1 .

The equation of $D_\tau \cap X_{\sigma_0}$ in $X_{\sigma_0} \cong \mathbb{C}^2$ is $z^v = 0$ where v is the generator of $S_\sigma = \check{\sigma} \cap M$ which does not vanish on τ (see 4.2). For example, in $D_\tau \cap X_{\sigma_0}$, the covector e_1^* does not vanish on τ , then D_τ is defined by the equation $x = 0$ in $X_{\sigma_0} = \text{Spec}(\mathbb{C}[x, y])$.

In the same way, D_τ is defined by $xy^a = 0$ in $X_{\sigma_1} = \text{Spec}(\mathbb{C}[xy^a, y^{-1}])$.

The ideal \mathcal{I} defining the curve D_τ is $\mathcal{I}|_{X_{\sigma_0}} = (x)$ in R_{σ_0} and $\mathcal{I}|_{X_{\sigma_1}} = (xy^a)$ in R_{σ_1} . The curve D_τ is covered by two affine charts

$$V_0 = D_\tau \cap X_{\sigma_0} = \text{Spec}(\mathbb{C}[y]) \quad \text{and} \quad V_1 = D_\tau \cap X_{\sigma_1} = \text{Spec}(\mathbb{C}[y^{-1}]).$$

Let us remember that an ideal defined by rational functions f_i on elements U_i of a covering of X determines a 1-cocycle defined by f_i/f_j on $U_i \cap U_j$. The ideal $\mathcal{I}/\mathcal{I}^2$ is trivial and generated by x in the first chart, it is trivial and generated by xy^a in the second one. Then it defines a 1-cocycle with value in $\mathcal{O}_{D_\tau}^*$, and whose value is y^a on $V_0 \cap V_1$. Therefore it can be represented as an invertible sheaf $\mathcal{O}(a)$ on D_τ .

The self-intersection number of D_τ is the degree of the normal bundle to the embedding of the curve $D_\tau \cong \mathbb{P}^1$ in X , i.e. the line bundle $N = \mathcal{O}(-D_\tau) = \mathcal{O}(-a)$ on \mathbb{P}^1 . One has (see also [10], VII Lemma 6.2):

$$(D_\tau \cdot D_\tau)_X = -a$$

If X is a complete surface,

$$(D_\tau \cdot D_\tau)_X = \int_D c_1(N)$$

so we obtain

$$(D_\tau \cdot D_\tau)_X = c_1(N) = -c_1(\mathcal{I}/\mathcal{I}^2) = -a$$

and as $\mathcal{I}/\mathcal{I}^2$ is the dual of the normal sheaf N , one has $c_1(\mathcal{I}/\mathcal{I}^2) = a$.

Example 6.1 The example of the cylinder and the Möbius strip gives an intuition of that fact: The circle S at level 0 is a divisor in the two varieties. In the cylinder, the

tangent bundle to S and the normal bundle to S are trivial and $(S.S)_X = 0$. In the Möbius strip, the tangent bundle to S is trivial, but the normal bundle is not trivial. A small deformation of S into S' meeting S in one point gives $(S.S) = -1$.

On the previous example, one has

$$av_1 = v_0 + v_2$$

Remark 6.1 The toric variety corresponding to the fan of Figure 19 is $\mathcal{O}_{\mathbb{P}^1}(-a)$ on \mathbb{P}^1 . On the other hand, the toric variety corresponding to the fan

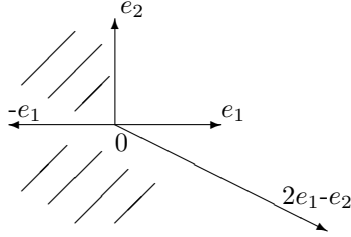

Fig. 24.

is $\mathcal{O}_{\mathbb{P}^1}(a)$ on \mathbb{P}^1 . The Hirzebruch surface is obtained as the gluing of these two bundles (see Example 3.7). We get a projective line bundle on \mathbb{P}^1 , obtained by fiberwise compactification of the total space of the bundle $\mathcal{O}_{\mathbb{P}^1}(a)$.

In a similar way, one obtains

$$\begin{aligned} 0v_2 &= v_1 + v_3 \\ -av_3 &= v_2 + v_0 \\ 0v_0 &= v_1 + v_3 \end{aligned}$$

Drawing the divisors (homeomorphic to \mathbb{P}^1) with their self-intersections (written in bold), one has the following picture:

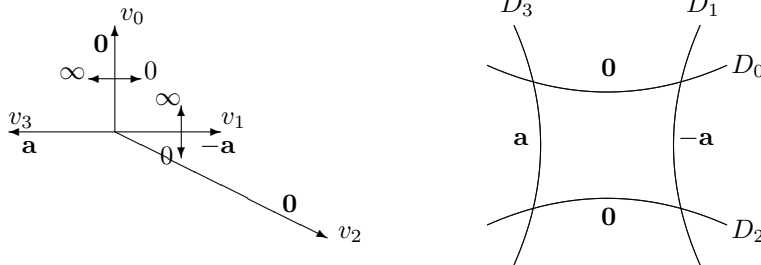

Fig. 25.

6.2 Toric surfaces

The compact smooth toric surfaces are given by a sequence of lattice points $v_0, v_1, \dots, v_{d-1}, v_d = v_0$ (in trigonometric order) in $N = \mathbb{Z}^2$. The successive pairs (v_i, v_{i+1}) are generators of the lattice, i.e. $\det(v_i, v_{i+1}) = \pm 1$. In other words, the volume of the parallelepiped constructed on v_i and v_{i+1} is 1.

We have $v_2 = -v_0 + a_1v_1$ and in general $v_{i+1} = -v_{i-1} + a_iv_i$, for $1 \leq i \leq d$.

Possible configurations are limited by constraints. For example, the following situation is impossible: v_j is situated in the angle $(v_{i+1}, -v_i)$ and v_{j+1} in the angle $(-v_i, -v_{i+1})$. The reason is that if $v_j = -av_i + bv_{i+1}$ and $v_{j+1} = -cv_i - dv_{i+1}$ with all coefficients $a, b, c, d > 0$, we must have

$$\det \begin{pmatrix} -a & b \\ -c & -d \end{pmatrix} = 1$$

but $ad + bc \geq 2$, which is impossible.

We have the Theorem :

Theorem 6.1 *The only compact smooth toric surface given by $d = 3$ lattice points is $X_\Delta = \mathbb{P}^2$. If $d = 4$, then X_Δ is an Hirzebruch surface \mathcal{H}_a . In particular if $a = 0$, then $X_\Delta = \mathbb{P}^1 \times \mathbb{P}^1$.*

Theorem 6.2 *All compact toric surfaces are obtained from \mathbb{P}^2 or an Hirzebruch surface \mathcal{H}_a by a succession of blowing-up in fixed points of the torus action.*

That means that, if $d \geq 5$, there is j , $1 \leq j \leq d$ such that $v_j = v_{j-1} + v_{j+1}$. In general, one has:

$$\begin{pmatrix} v_i \\ v_{i+1} \end{pmatrix} = \begin{pmatrix} 0 & 1 \\ -1 & a_i \end{pmatrix} \begin{pmatrix} v_{i-1} \\ v_i \end{pmatrix}$$

and the integers a_i must satisfy

$$\begin{pmatrix} 0 & 1 \\ -1 & a_1 \end{pmatrix} \begin{pmatrix} 0 & 1 \\ -1 & a_2 \end{pmatrix} \cdots \begin{pmatrix} 0 & 1 \\ -1 & a_d \end{pmatrix} = \begin{pmatrix} 1 & 0 \\ 0 & 1 \end{pmatrix}$$

Lemma 6.1 *The sequence of integers a_i satisfies*

$$a_1 + a_2 + \cdots + a_d = 3d - 12.$$

6.3 Playing with multiplicities

The operation of adding $v' = v_j + v_{j+1}$ between v_j and v_{j+1} changes the sequence of integers a_1, a_2, \dots, a_d by adding 1 to a_j and a_{j+1} and inserting the integer 1 between them. Part of the sequence of vertices is, before the operation: $(v_{j-1}, v_j, v_{j+1}, v_{j+2})$ with:

$$a_j v_j = v_{j-1} + v_{j+1} \quad \text{and} \quad a_{j+1} v_{j+1} = v_j + v_{j+2}$$

It becomes $(v_{j-1}, v_j, v', v_{j+1}, v_{j+2})$ with $a_j v_j = v_{j-1} + v' - v_j$ and $a_{j+1} v_{j+1} = v' - v_{j+1} + v_{j+2}$, then:

$$(a_j + 1)v_j = v_{j-1} + v', \quad 1.v' = v_j + v_{j+1} \quad \text{and} \quad (a_{j+1} + 1)v_{j+1} = v' + v_{j+2}.$$

Each edge τ_i , generated by v_i determines a divisor $D_i \cong \mathbb{P}^1$ in X_Δ with multiplicity $(-a_i)$. The normal bundle to the embedding is the line bundle $\mathcal{O}(-a_i)$ in \mathbb{P}^1 . The curves D_i meet transversally or are disjoint. If $a_i v_i = v_{i-1} + v_{i+1}$, the self intersection (D_i, D_i) is $-a_i = -\det(v_{i-1}, v_{i+1})$. One has the following picture:

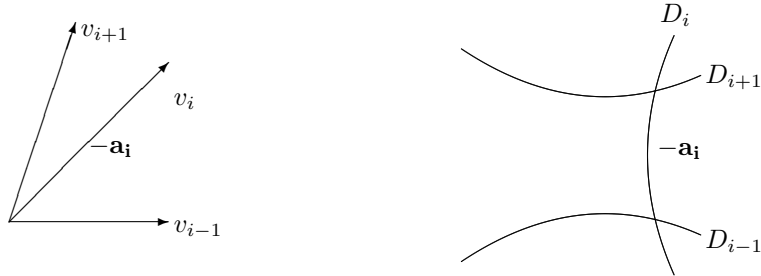
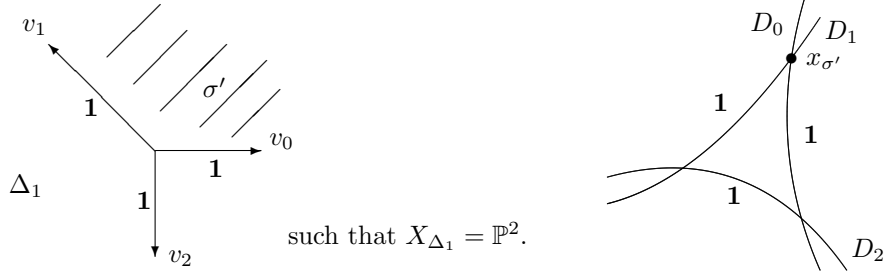

Fig. 26.

where the role of the D_i changes as basis and fibre, passing from one of the divisor to the following.

Example 6.2 Let us consider the following fan:



By blowing up in the point $x_{\sigma'}$, we obtain:



where interior of the right picture is a torus and the point $x_{\sigma''}$ is a fixed point for the torus action. Blowing up that point, we obtain:



We can contract D_0 which has self-intersection -1 . That means adding 1 to self-intersection of neighborhood divisors:



Fig. 27.

We obtain $X_{\Delta_4} = \mathbb{P}^1 \times \mathbb{P}^1$ whose real picture is a torus:

Fig. 28.

The sequence of blowing-up and contraction can be written:

$$X_{\Delta_1} \longleftarrow X_{\Delta_2} \longleftarrow X_{\Delta_3} \longrightarrow X_{\Delta_4}$$

Example 6.3 Another example of such a process is the following:

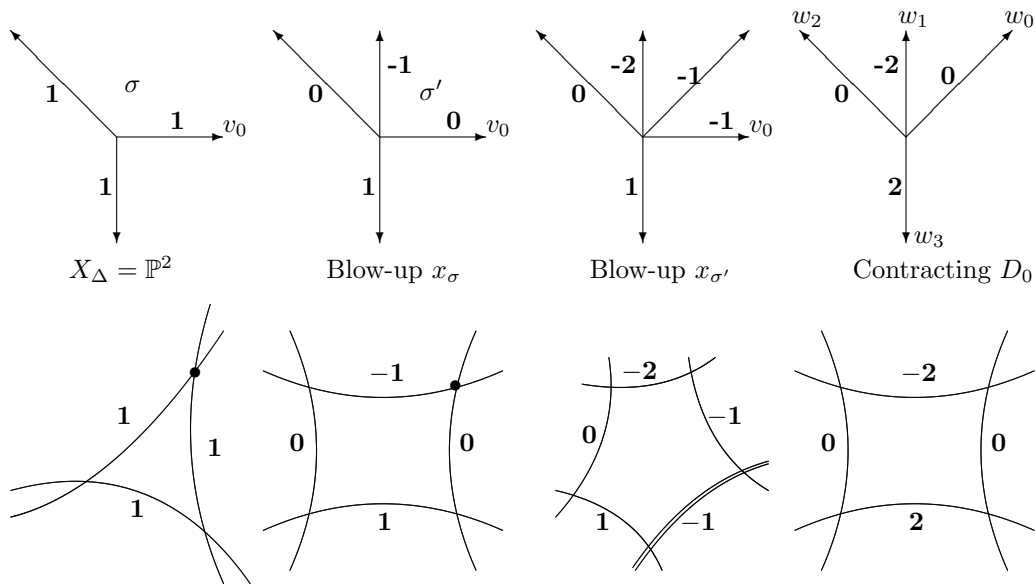

Fig. 29.

The toric variety associated to the last fan is the blow-up of a quadratic cone in its vertex. In the last fan, one has $2w_1 = w_0 + w_2$, then the fan (w_0, w_1, w_2) corresponds to the total space of the bundle $\mathcal{O}_{\mathbb{P}^1}(-2)$ over \mathbb{P}^1 . The fiber becomes the basis of the following bundle.

6.4 Resolution of singularities

Let us remember the Example 2.4 for which $X_{\sigma} = \mathbb{C}^2$ and the cone generated by e_1 and e_2 corresponds to the fixed point $x_{\sigma} = 0$ in \mathbb{C}^2 .

The following example will be the model for resolving singularities, i.e. the blow-up in a fixed point $x = x_{\sigma}$ of the torus action. That is obtained by adding the sum of two adjacent vectors generating σ .

Example 6.4 Consider the following fan

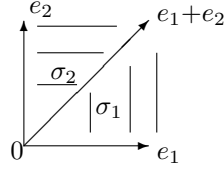

Fig. 30.

$S_{\sigma_1} = \{e_1^* - e_2^*, e_2^*\}$ and $S_{\sigma_2} = \{e_1^*, -e_1^* + e_2^*\}$. Then $X_{\sigma_1} = \mathbb{C}_{(u_1, u_2)} = \mathbb{C}_{(z_1 z_2^{-1}, z_2)}^2$ and $X_{\sigma_2} = \mathbb{C}_{(u_3, u_4)} = \mathbb{C}_{(z_1, z_1^{-1} z_2)}^2$. Let us glue together X_{σ_1} and X_{σ_2} along X_τ . The monoid S_τ is generated by $(e_1^* - e_2^*, e_2^*, e_1^*, -e_1^* + e_2^*)$ and $R_\tau = \mathbb{C}[u_1, u_2, u_3, u_4]$ such that $u_1 u_2 = u_3$ and $u_1 u_4 = 1$. Then X_τ is represented

$$\begin{aligned} \text{in } X_{\sigma_1}, \quad & \text{as } \mathbb{C}_{u_1}^* \times \mathbb{C}_{u_2} = \mathbb{C}_{z_1 z_2^{-1}}^* \times \mathbb{C}_{z_2} = X_{\sigma_1} \setminus (u_1 = 0) \\ \text{in } X_{\sigma_2}, \quad & \text{as } \mathbb{C}_{u_3} \times \mathbb{C}_{u_4}^* = \mathbb{C}_{z_1} \times \mathbb{C}_{z_1^{-1} z_2}^* = X_{\sigma_2} \setminus (u_4 = 0) \end{aligned}$$

and these two smooth varieties are glued using the changement of coordinates $(u_1, u_2) \mapsto (u_1 u_2, u_1^{-1})$.

Let us describe another way : The corresponding toric variety is a subvariety of $\mathbb{C}_{(z_1, z_2)}^2 \times \mathbb{P}^1_{(t_0, t_1)}$ given by $z_1 t_1 = z_2 t_0$ covered by two varieties X_0 and X_1 where $t_0 \neq 0$ and $t_1 \neq 0$. On X_0 , there are coordinates z_1 and $t_1/t_0 = z_2/z_1$, i.e. X_{σ_1} ; on X_1 , there are coordinates z_2 and $t_0/t_1 = z_1/z_2$, i.e. X_{σ_2} . Obtained variety is the blow-up of a point in \mathbb{C}^2 (the origin is replaced by \mathbb{P}^1 , i.e. by directions through the point 0).

Example 6.5 Let us consider the following fan (cone) Δ and its subdivision Δ' :

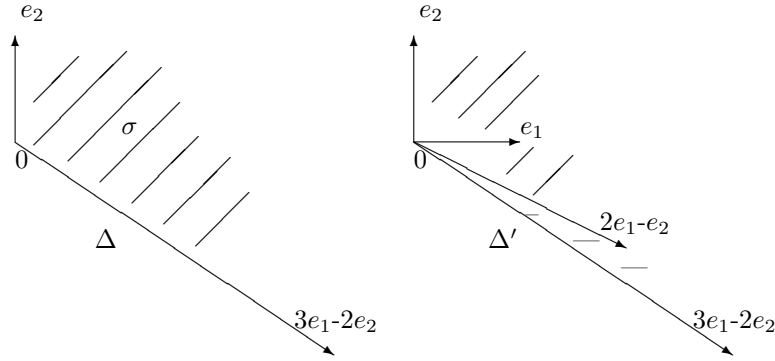

Fig. 31. Resolution of singularities.

The fan Δ' is a regular fan, hence $X_{\Delta'}$ is a smooth toric variety. The identity map of N provides a map $X_{\Delta'} \rightarrow X_\Delta$ which is birational proper. It is an isomorphism on the open torus \mathbb{T} contained in each. This is the first example (and standard one) of resolution of singularities.

The procedure is the following : beginning with the cone σ generated by the two vectors $v = e_2$ and $v' = 3e_1 - 2e_2$, we add primitive vectors (here $v_1 = e_1$ and $v_2 = 2e_1 - e_2$) such that, with $v_0 = v$ and $v_3 = v'$, we have

$$\lambda_i v_i = v_{i-1} + v_{i+1} \quad i = 1, 2$$

For $i = 1, 2$, the vectors v_i correspond to exceptional divisors $D_i \cong \mathbb{P}^1$ in $X_{\Delta'}$ and their self-intersection are $(D_i, D_i) = -\lambda_i$ (see 6.1). In this particular case, we obtain two exceptional divisors with self-intersection -2 .

The previous situation can be generalized for all singularity of dimension 2. If σ is a cone which is not generated by a basis of N , then we can choose generators e_1 and e_2 for N such that σ is generated by $v = e_2$ and $v' = me_1 - ke_2$ with $0 < k < m$ and $(k, m) = 1$.

PROOF: Every minimal generator along a ray of σ is part of a basis of \mathbb{Z}^2 : $(0, 1)$ and the second one is (m, x) for $m > 0$. Applying a lattice automorphism

$$\begin{pmatrix} 1 & 0 \\ c & 1 \end{pmatrix} \begin{pmatrix} m & 0 \\ x & 1 \end{pmatrix} = \begin{pmatrix} m & 0 \\ cm + x & 1 \end{pmatrix}$$

we see that x can be modified arbitrarily modulo m , then we can take $x = -k$, with $0 \leq k < m$. If $x \equiv 0 \pmod{m}$, then σ is generated by a basis and X_σ is smooth.

On the other hand, $(k, m) = 1$ follows from the fact that the vector $(m, -k)$ is a minimal generator along the ray.

We can insert the line going through the vector e_1 . The cone generated by e_1 and e_2 corresponds to a smooth open subset. The cone generated by e_1 and $me_1 - ke_2$ provides a variety whose singular point is “less” singular than the previous one. In fact, if one turns the picture by 90° , one obtains

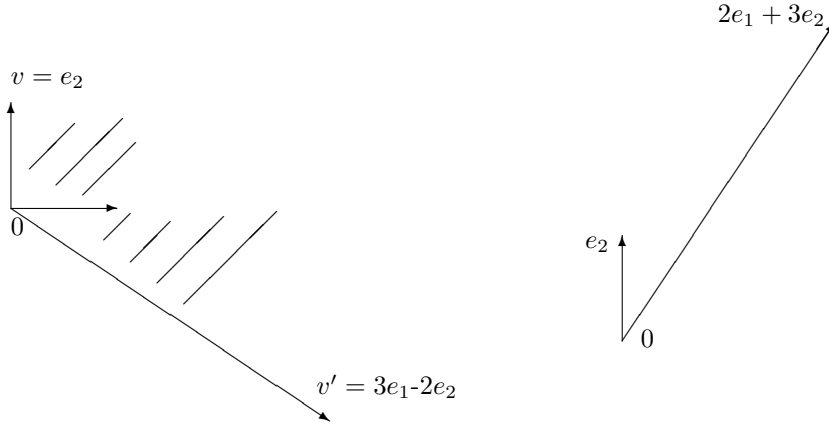

Fig. 32.

and the vector becomes

$$\begin{pmatrix} 1 & 0 \\ c & 1 \end{pmatrix} \begin{pmatrix} k & 0 \\ mx & 1 \end{pmatrix} = \begin{pmatrix} k & 0 \\ ck + m & 1 \end{pmatrix}$$

putting $m_1 = k$ and $k_1 = -ck - m$, we obtain the new vector $(m_1, -k_1)$. We have in fact the general algorithm:

Algorithm: Let us consider integer numbers $(m, -k)$ such that $0 \leq k < m$ and $(k, m) = 1$, there exist integer numbers $(m_1, -k_1)$ such that

$$m_1 = k \quad k_1 = a_1 k - m, \quad \text{with} \quad a_1 \geq 2, \quad 0 \leq k_1 < m_1, \quad (k_1, m_1) = 1.$$

If $k_1 = 0$, all cones are regular. In the contrary case, we continue the process, writing

$$\frac{m}{k} = a_1 - \frac{k_1}{m_1} = a_1 - \frac{1}{\frac{k_1}{m_1}}$$

and using one more time the algorithm in the same way than the Euclidean algorithm. We obtain a continued fraction, but with alternative signs:

$$\frac{m}{k} = a_1 - \frac{1}{a_2 - \frac{1}{\dots - \frac{1}{a_r}}}$$

where all $a_i \geq 2$.

We call continued fraction of Hirzebruch-Jung the fraction obtained in this way as an expression of m/k .

Example 6.6 Let us consider the cone σ generated by the two vectors $v = e_2$ and $v' = 12e_1 - 5e_2$. The first step is to consider the Hirzebruch-Jung fraction of $12/5$:

$$\frac{12}{5} = 3 - \frac{1}{2 - \frac{1}{3}}$$

then $a_1 = 3$, $a_2 = 2$ and $a_3 = 3$. We can give the explicit decomposition of σ by vectors v_i , such that $a_i v_i = v_{i-1} + v_{i+1}$, $v_0 = v'$, $v_r = e_1$ and $v_{r+1} = v = e_2$.

$$\begin{array}{ccccc} v_0 & v_1 & v_2 & v_3 & v_4 \\ \left(\begin{array}{ccccc} 12 & 5 & 3 & 1 & 0 \\ -5 & -2 & -1 & 0 & 1 \end{array} \right) \\ \mathbf{3} & \mathbf{2} & \mathbf{3} & & \end{array}$$

For example $3v_1 = v_0 + v_2$. Thus, we obtain the following decomposition of the cone σ as a regular fan:

Fig. 33.

Remark 6.2 a) The rays obtained by this procedure are exactly those passing through the vertices of the boundary of the convex hull of the non-zero points of $\sigma \cap N$. The set $\{v_0, \dots, v_{r+1}\}$ is a minimal set of generators of the semi-group $\sigma \cap N$.

b) There are r vertices added between $v_0 = v$ and $v_{r+1} = v'$. They correspond to rays and to exceptional divisors D_i with $(D_i, D_i) = -a_i$ and $D_i \cap D_{i+1} = x_\sigma$ is a fixed point corresponding to the cone σ generated by v_i and v_{i+1} .

Example 6.7 Let σ be the cone generated by e_2 and $(k+1)e_1 - ke_2$. Then S_σ is generated by

$$v_1 = e_1^* \quad v_2 = ke_1^* + (k+1)e_2^* \quad v_3 = e_1^* + e_2^*$$

with $(k+1)v_3 = v_1 + v_2$. One obtains

$$R_\sigma = \mathbb{C}[x_1, x_2, x_3]/(x_3^{k+1} - x_1x_2)$$

and the toric variety has a rational double point of type A_k . The resolution of singularities provides k exceptional divisors, isomorphic to \mathbb{P}^1 and with self-intersection -2 . They are obtained by the decomposition in Hirzebruch-Jung fraction of $k+1/k$.

Property 6.1 [18] *The algebra $R_\sigma = \mathbb{C}[S_\sigma]$ has a minimal number of generators $\{u^{s_i}v^{t_i}, 1 \leq i \leq \ell\}$ where ℓ and the exponents are determined in the following way:*

Let $b_2, \dots, b_{\ell-1}$ be the integers (≥ 2) which appear in the Hirzebruch-Jung continuous fraction of $m/(m-k)$. Then one has

$$\begin{array}{lll} s_1 = m & s_2 = m - k & s_{i+1} = b_i s_i - s_{i-1} \\ t_1 = 0 & t_2 = 1 & t_{i+1} = b_i t_i - t_{i-1} \end{array}$$

for $2 \leq i \leq \ell - 1$.

Developments

In the general case ($n \geq 2$), a fan Δ in a lattice N can be subdivided by adding vectors in order to provide a simplicial fan. For each simplicial cone of dimension k , let (v_1, \dots, v_k) the primitive vectors along the rays of σ , one can define the multiplicity of σ as the index of the lattice generated by the vectors v_i in the lattice generated by σ :

$$\text{mult}(\sigma) = [N_\sigma : \mathbb{Z}v_1 + \dots + \mathbb{Z}v_k]$$

(for example, in Example 1.5, $u = e_1 = 1/2v_1 + 1/2v_2$ and $\text{mult}(\sigma) = 2$).

The affine toric variety X_σ is non singular if and only if $\text{mult}(\sigma) = 1$.

The following Lemma is known as Minkowski Theorem:

Lemma 6.2 *If $\text{mult}(\sigma) > 1$, there is a point v in the lattice such that $v = \sum \lambda_i v_i$ for $0 \leq \lambda_i < 1$. For this v minimal on its ray, the multiplicities of the subdivided k -dimensional cones are $\lambda_i \cdot \text{mult}(\sigma)$, with such a cone for every non zero λ_i .*

For surfaces, one obtains $a_i = \text{mult}(\text{cone}(v_i, v_{i+1}))$, which corresponds to the previous procedure.

The following Theorem is a consequence of the Lemma:

Theorem 6.3 *For every toric variety X_Δ there is a refinement Δ' of Δ such that the induced map $X_{\Delta'} \rightarrow X_\Delta$ is a resolution of singularities.*

The different possibilities of refinements lead to the “flip-flop” theory and the relation to the Mori program.

On another hand, the fruitful Oka theory of toric resolutions presents toric modifications as finite sequence of blowing-ups (case of curves and surfaces) (see [17]).

7 More algebraic geometry

7.1 Poincaré homomorphism.

The toric varieties are examples of pseudovarieties of (real) even dimension. By definition, a pseudovariety X of (real) dimension $2n$ is a connected topological space such that there is a closed subspace Σ such that :

- (a) $X - \Sigma$ is an oriented smooth variety, of dimension $2n$, dense in X ,
- (b) $\dim \Sigma \leq 2n - 2$.

A $2n$ -pseudovariety admits a fundamental class in integer homology with closed supports $[X] \in H_{2n}^{\text{cl d}}(X)$. The Poincaré morphism

$$H^i(X) \longrightarrow H_{2n-i}^{\text{cl d}}(X)$$

is the cap-product by the fundamental class. If X is smooth, it is an isomorphism.

An example of pseudovariety for which the Poincaré homomorphism is not an isomorphism is given by the toric variety of Example 2.8 (with $q=1$). We have $H^2(X) = 0$ and $H_2^{\text{cl d}}(X) = \mathbb{Z}_p$.

Theorem 7.1 *Let X be a normal compact pseudovariety, there is a commutative diagram :*

$$\begin{array}{ccc} \mathcal{C}(X) & \hookrightarrow & \mathcal{W}(X) \\ \downarrow c^1 & & \downarrow \kappa \\ H^2(X) & \xrightarrow{\cap [X]} & H_{2n-2}(X) \end{array}$$

where the horizontal arrow below is the Poincaré morphism of the pseudovariety X .

If X is a compact toric variety, one has the following result :

Theorem 7.2 [3] *Let $X = X_\Delta$ be a compact toric variety, there is a commutative diagram :*

$$\begin{array}{ccc} \mathcal{C}^{\mathbb{T}}(X) & \hookrightarrow & \mathcal{W}^{\mathbb{T}}(X) \\ \downarrow \cong & & \downarrow \cong \\ H^2(X) & \xrightarrow{\cap [X]} & H_{2n-2}(X) \end{array}$$

where the vertical isomorphisms are induced by the morphisms c_1 and κ of the previous theorem.

We obtain by this way an interpretation of the Poincaré morphism in terms of divisors, for compact toric varieties. In particular, the Poincaré morphism $H^2(X) \longrightarrow H_{2n-2}(X)$ is injective.

Definition 7.1 *The toric variety X is said degenerate if it can be written $X = Y \times \mathbb{T}''$ where \mathbb{T}'' is a (proper) subtorus of \mathbb{T} and Y is a toric variety relatively to the torus \mathbb{T}' such that $\mathbb{T} = \mathbb{T}' \times \mathbb{T}''$.*

In the non degenerate case, the Theorem 7.2 is still valid, using homology with closed supports. In the general case, one has the following result:

Theorem 7.3 [3] *Let $X = X_\Delta$ be a n -dimensional toric variety containing a toric factor \mathbb{T}'' of dimension $n - d$, then we have the following isomorphisms :*

$$i) \quad H^1(X) \cong H_{2n-1}^{\text{clid}}(X) \cong H^1(\mathbb{T}'') \cong H_{2n-2d-1}^{\text{clid}}(\mathbb{T}'') \cong \mathbb{Z}^{n-d};$$

the homomorphisms c^1 and κ are injective and there are isomorphisms

$$ii) \quad H^2(X) \cong \mathcal{C}^\mathbb{T}(X) \oplus H^2(\mathbb{T}'') \cong \mathcal{C}^\mathbb{T}(X) \oplus \mathbb{Z}^b;$$

$$iii) \quad H_{2n-2}^{\text{clid}}(X) \cong \mathcal{W}^\mathbb{T}(X) \oplus H_{2n-2d-2}^{\text{clid}}(\mathbb{T}'') \cong \mathcal{W}^\mathbb{T}(X) \oplus \mathbb{Z}^b$$

with $b := \binom{n-d}{2}$, such that the following diagram commutes :

$$\begin{array}{ccc} \mathcal{C}^\mathbb{T}(X) \oplus H^2(\mathbb{T}'') & \longrightarrow & \mathcal{W}^\mathbb{T}(X) \oplus H_{2n-2d-2}^{\text{clid}}(\mathbb{T}'') \\ c^1 \oplus \text{pr}^* \downarrow \cong & & \kappa \oplus \text{pr}^* \downarrow \cong \\ H^2(X) & \xrightarrow{\cap[X]} & H_{2n-2}^{\text{clid}}(X) \quad . \end{array}$$

This diagram can be completed by the intersection homology of X_Δ which admits also an interpretation in terms of divisors (see [4]).

7.2 Betti cohomology numbers

Let X be an algebraic variety, we denote the (cohomological) Betti numbers by $\beta_j = \dim H^j(X)$

Let X_Δ be a compact toric variety, we denote by d_k the number of k -dimensional cones in Δ .

Proposition 7.1 [11] 4.5. *Let X_Δ be a nonsingular projective toric variety, then $\beta_j = 0$ for odd j and*

$$\beta_{2k} = \sum_{i=k}^n (-1)^{i-n} \binom{i}{k} d_{n-i}$$

Let us write the Poincaré polynomial $P_X(t) = \sum \beta_j t^j$, then

$$P_X(t) = \sum_{k=0}^n \beta_{2k} t^{2k} = \sum_{i=0}^n d_{n-i} (t^2 - 1)^i = \sum_{k=0}^n d_k (t^2 - 1)^{n-k}$$

For example, the Euler characteristic is

$$\chi(X) = \sum (-1)^j \beta_j = P_X(-1) = d_n$$

Conversely, one has

$$d_k = \sum_{i=0}^k \binom{n-i}{n-k} \beta_{2(n-i)}$$

The proof of the Proposition uses the mixed Hodge structure on cohomology groups with compact supports. the Proposition is also true if Δ is simplicial and complete (and in that case, the proof uses intersection homology).

7.3 Betti homology numbers

Let us consider the general case of a fan, non necessarily complete and regular. Let us denote by α the dimension of the smallest linear subspace containing Δ .

Proposition 7.2

$$b_{2n-2} = \dim H_{2n-2}^{\text{old}}(X) = d_1 - \alpha + \binom{n - \alpha}{2}$$

$$\beta_2 = \dim H^2(X) = b_{2n-2} - r(\Delta)$$

where $r(\Delta)$ is the rank of the matrix of relations of the non simplicial cones in Δ .

Example 7.1 Let us consider in \mathbb{R}^3 the fan generated by the vertices $v_1 = (1, 1, 1)$, $v_2 = (-1, 1, 1)$, $v_3 = (0, -1, 1)$ and for $i = 1, 2, 3$ the vertices $v_{i+3} = v_i - (0, 0, 2)$.

Fig. 34.

Three of the cones are not simplicial: τ_1, τ_2 and τ_3 . One obtains the following matrix of relations with vectors v_i in columns entries and non simplicial cones τ_j in rows entries (for example $v_1 - v_2 - v_4 + v_5 = 0$):

$$\begin{pmatrix} 1 & -1 & 0 & -1 & 1 & 0 \\ 0 & 1 & -1 & 0 & -1 & 1 \\ -1 & 0 & 1 & 1 & 0 & -1 \end{pmatrix}$$

The rank of the matrix is $r(\Delta) = 2$, then

$$b_{2n-2} = b_4 = 6 - 3 = 3 \quad \text{and} \quad \beta_2 = b_4 - r(\Delta) = 3 - 2 = 1$$

In that case, the toric variety is projective. Let us now change v_1 into $v'_1 = 2v_1 - v_2 = (3, 1, 1)$, then $r(\Delta) = 3$, $\beta_2 = 0$ and X_Δ is not projective.

Property 7.1 *Let us consider a 3-dimensional compact toric variety, then*

$$\beta_0 = \beta_6 = 1, \quad \beta_1 = \beta_5 = 0, \quad \beta_3 = \beta_2 - d_3 + d_1, \quad \beta_4 = d_1 - 3$$

7.4 Characteristic classes.

Let X_Δ be a smooth toric variety. The Poincaré homomorphism is an isomorphism between $H^k(X_\Delta)$ and $H_{2n-k}^{\text{old}}(X_\Delta)$ for every k . The Chern characteristic classes of

X_Δ are usually defined in cohomology but their image in homology can be easily described in terms of the orbits. In fact, the total homology Chern class of X_Δ is:

$$\begin{aligned} c(X_\Delta) &= \prod_{i=1}^q (1 + D_i) \\ &= \sum_{\sigma \in \Delta} [V_\sigma] \end{aligned}$$

where $D_i = V_{\tau_i}$ are the divisors corresponding to the edges of Δ . The intersection product is given by

$$D_i \cdot V_\sigma = \begin{cases} V_\gamma & \text{if } \sigma \text{ and } \tau_i \text{ span a cone } \gamma \text{ in } \Delta \\ 0 & \text{in the other case.} \end{cases}$$

This result has been generalized for singular toric varieties by Ehlers (non published) and independently by [2]. More precisely, it is well known that there is no cohomology Chern classes for a singular algebraic variety. In homology we can define the Schwartz-MacPherson classes which generalize homology Chern classes and we obtain the following result :

Theorem 7.4 ([2]) *Let X_Δ be any toric variety, the total Schwartz-MacPherson class of X_Δ is given by :*

$$c(X_\Delta) = \sum_{\sigma \in \Delta} [V_\sigma] \quad \in H_*(X_\Delta).$$

8 Examples of applications

In this section, we give some applications of the theory of toric varieties. Part of them can be found in [11], and on the algebraic geometry point of view in [7] (applications to Algebraic coding theory, Error-correcting codes, Integer programming and combinatorics, Computing resultants and solving equations). Applications to Symplectic Manifolds will be found in the book of M. Audin [1].

8.1 Sommerville relations

Let P be a convex simplicial polytope in \mathbb{R}^3 . Let us denote by f_0 the number of vertices, f_1 the number of edges and f_2 the number of faces. One has the relations

$$f_0 - f_1 + f_2 = 2 \quad (Euler) \quad (1)$$

$$3f_2 = 2f_1 \quad (2)$$

$$f_0 \geq 4 \quad (3)$$

The second relation comes from the fact that each face is a triangle, then each face has three edges and each edge appears as an edge of two faces. A polytope bounding a solid must have more than 4 vertices, this gives the third relation.

Reciprocally, every triple of integers satisfying (1), (2), (3) can be realized from a convex simplicial polytope in \mathbb{R}^3 .

Let us consider the case $n = 4$, then we have the relations

$$f_0 - f_1 + f_2 - f_3 = 2 \quad (Euler) \quad (4)$$

$$f_2 = 2f_3 \quad (5)$$

$$f_0 \geq 5 \quad (6)$$

the second relation is due to the fact that every 3-simplex has 4 faces of dimension 2, and each of them is face of two 3-simplices. One has also

$$f_1 \leq 1/2f_0(f_0 - 1) \quad (7)$$

$$f_1 \geq 4f_0 - 10 \quad (8)$$

Relation (7) is the quadric inequality, valid in all dimensions and due to the fact that two vertices can be joined by at most one edge. The relation (8) is more complicated, representing a lower bound of the number of edges.

Example 8.1 If $f_0 = 5$, then $f_1 = f_2 = 10$ and $f_3 = 5$ are uniquely determined and correspond to the boundary of the standard 4-simplex.

Exercise. The conditions (4) to (8) give two possibilities for the sequence (f_0, f_1, f_2, f_3) with $f_0 = 6$. They are $(6, 14, 16, 8)$ and $(6, 15, 18, 9)$.

The sequence of f_i defines a sequence h_i (say h -numbers) by:

$$h_p = \sum_{i=p}^n (-1)^{i-p} \binom{i}{p} f_{n-i-1}$$

with $f_{-1} = 1$.

It is possible to obtain the sequence (h_0, \dots, h_n) in an easy way: let us write the sequence (f_0, \dots, f_{n-1}) on the left side of a triangle ($n + 1$ rows, we put $f_n = 0$) and number 1 on the right side. Let us write integers inside the triangle such that one is

obtained as the difference between the integer above it on the left and the one above it on the right. Then the bottom row gives the sequence of h_p , from left to right.

$$\begin{array}{ccccccc}
 & & & f_0 & & 1 & \\
 & & & & & & \\
 & & & f_1 & & f_0 - 1 & & 1 \\
 & & & & & & & & \\
 & & f_2 & & f_1 - f_0 + 1 & & f_0 - 2 & & 1 \\
 f_2 - f_1 + f_0 - 1 & & & & f_1 - 2f_0 + 3 & & & f_0 - 3 & & 1
 \end{array}$$

The Euler relation gives $h_0 = h_n$. For $n = 3$ and $n = 4$, the relations (1) - (2) (or (4) - (5)) give $h_0 = h_n$ and $h_1 = h_{n-1}$. The Dehn-Sommerville equations are generalization of this equation, i.e. $h_p = h_{n-p}$.

Theorem 8.1 *A sequence of integers $(f_0, f_1, \dots, f_{n-1})$ corresponds to the sequence “ $f_k =$ numbers of k -dimensional faces of a simplicial convex polytope” if and only if the corresponding h -numbers satisfy the following relations*

(1) the Dehn-Sommerville relations: $h_p = h_{n-p}, \forall 0 \leq p \leq \lfloor \frac{n}{2} \rfloor$

(2) (a) $h_p - h_{p-1} \geq 0$ for $1 \leq p \leq \lfloor \frac{n}{2} \rfloor$

and, if one writes

$$h_p - h_{p-1} = \binom{n_p}{p} + \binom{n_{p-1} + 1}{p-1} + \dots + \binom{n_r}{r}$$

with $n_p > n_{p-1} > \dots > n_r \geq r \geq 1$, then

(b) $h_{p+1} - h_p \leq \binom{n_p + 1}{p+1} + \binom{n_{p-1}}{p} + \dots + \binom{n_r + 1}{r+1}$ for $1 \leq p \leq \lfloor \frac{n}{2} \rfloor$

The idea of the proof is to construct $X = X_\Delta$ for a simplicial fan Δ such that $d_k =$ number of k -dimensional cones $= f_{k-1} =$ number of $(k-1)$ -dimensional faces of P .

The Theorem was conjectured by McMullen [14], then existence of a convex polytope whose face numbers satisfy the conditions was proved by Billera and Lee [5]. The proof of the necessity part is due to Stanley [19] who uses strong arguments such that Lefschetz Theorem for intersection homology and Decomposition Theorem.

8.2 Lattice points in a polytope

Given a bounded convex lattice polytope (with vertices on M), there is a procedure to determine the number of lattice points that are in P , i.e. $\text{card}(P \cap M)$. Firstly, we determine the complete fan Δ corresponding to P . There is an invariant Cartier divisor D on $X = X_\Delta$ such that $\mathcal{O}(D)$ is generated by its sections and these sections are linear combinations of the character functions χ^u for $u \in P \cap M$. The divisor D is given by a collection of elements $u(\sigma) \in M/M(\sigma)$ (see 4.4 and 5.2).

For every cone $\sigma \in \Delta$, let us denote P_σ the face of P corresponding to σ :

$$P_\sigma = P \cap (\sigma^\perp + u(\sigma))$$

In another words, $P_\sigma = P \cap (\sigma^\perp + u)$ for any u in M whose image in $M/M(\sigma)$ is $u(\sigma)$. The lattice $M(\sigma)$ determines a volume element on $\sigma^\perp + u(\sigma)$, whose dimension is the codimension of σ .

One has

$$\text{card}(P \cap M) = \sum_{\sigma \in \Delta} r_\sigma \text{Vol}(P_\sigma)$$

where the numbers r_σ have to be determined. That is provided by consideration of the Todd class:

The homology Todd class $Td(X)$ of an algebraic complex variety is an element of $H_*(X, \mathbb{Q})$,

$$Td(X) = Td_n(X) + \cdots + Td_0(X)$$

whose top class is the fundamental class $Td_n(X) = [X]$.

If X is non singular, one has $Td(X) = td(T_X) \cap [X]$ where T_X is the tangent bundle to X and td the usual cohomological Todd class (see [13]).

If X is a toric variety, then $Td_{n-1}(X) = \frac{1}{2} \sum [D_i]$ and the 0-dimensional class is $Td_0(X) = \{pt\}$.

The Todd class is a \mathbb{Q} -linear combination of the $[V_\sigma]$,

$$Td(X) = \sum_{\sigma \in \Delta} r_\sigma [V_\sigma] \quad r_\sigma \in \mathbb{Q}.$$

As an application of the Riemann-Roch Theorem one obtains (see [11], 5.3) that the coefficients r_σ in formulae of $\text{card}(P \cap M)$ and $Td(X)$ are the same.

In the same way, if we denote $b_k = \sum_{\text{codim} \sigma = k} r_\sigma \text{Vol}(P_\sigma)$, then

$$\text{card}(\lambda P \cap M) = \sum_{k=0}^n b_k \lambda^k$$

where $\lambda P = \{\lambda.v : v \in P\}$, so λP corresponds to the divisor λD .

In dimension 2, the situation is easy, one has:

$$Td(X) = [X] + \frac{1}{2} \sum [D_i] + \{pt\}$$

and one obtains the Pick's formula, for convex rational polytope in the plane

$$\text{card}(P \cap M) = \text{Area}(P) + \frac{1}{2} \text{Perimeter of } P + 1.$$

Let us consider the following example:

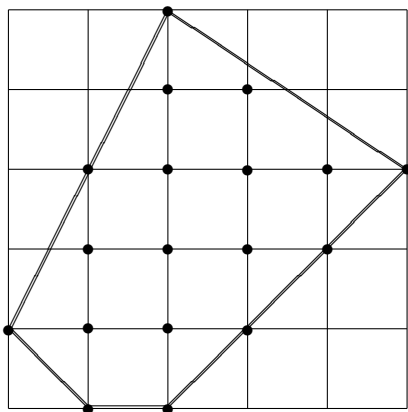

Fig. 35.

The area of P is 13, the perimeter (number of segments between two integer points of the boundary of P) is 8. We obtain

$$\text{card}(P \cap M) = 13 + \frac{8}{2} + 1 = 18.$$

In a general way,

$$\text{card}(\lambda P \cap M) = 13\lambda^2 + \frac{8}{2}\lambda + 1.$$

If $\lambda = -1$, one obtains the number of interior points inside $P \cap M$, which is 6 in this example.

Let us remark that conversely, the knowledge of the number of integer points gives the r_σ and the Todd class.

The number of \mathbb{F}_q -valued points in X , i.e. $\text{card}(X(\mathbb{F}_q))$ is of importance in incoding theory, being the first step to construct codes. The number of \mathbb{F}_q -valued points in the torus $(\mathbb{C}^*)^k$ is $(q-1)^k$, so

$$\text{card}(X(\mathbb{F}_q)) = \sum d_{n-k}(q-1)^k.$$

8.3 Magic squares

Magic squares fascinated by their mystery. It is interesting to see how they appeared in art representations as well in Japan as in Europe. An old kimono, in the Kyoto National Museum, is pictured with 2×2 and 3×3 magic squares. The famous engraving “Melancholia” by Albrecht Dürer contains the magic square

$$\begin{pmatrix} 16 & 3 & 2 & 13 \\ 5 & 10 & 11 & 8 \\ 9 & 6 & 7 & 12 \\ 4 & 15 & 14 & 1 \end{pmatrix}$$

whose all sums of rows and columns are equal to 34. This magic square satisfies supplementary properties: all integers $1, 2, \dots, n^2$ appear one (and only one) time, also, the sum of the two diagonals is equal to 34.

The problem we are interested with is the following: Given n and s , how many $n \times n$ magic squares with $m_{ij} \geq 0$ for all i, j and whose all sums of rows and columns are s can we write?

For $n = 2$, there are $s + 1$ magic squares with sum s .

There are 6 magic squares with $n = 3$ and $s = 1$ (see below)

There are 21 magic squares with $n = 3$ and $s = 2$

There are 55 magic squares with $n = 3$ and $s = 3 \dots$

The set of $(n \times n)$ -magic squares can be viewed as the set of solutions in $\mathbb{Z}_{\geq 0}^{n \times n}$ of a system of linear equations with integer coefficients, in the following way. Let us consider the case $n = 3$ and the matrix $M = (m_{ij})$. The condition “All rows and columns of M are equal” appear as 5 independent equations on the entries of the matrix

$$\vec{m} = (m_{11}, m_{12}, m_{13}, m_{21}, \dots, m_{33})^T$$

Let us define the 5×9 -matrix A by

$$A = \begin{pmatrix} 1 & 1 & 1 & -1 & -1 & -1 & 0 & 0 & 0 \\ 1 & 1 & 1 & 0 & 0 & 0 & -1 & -1 & -1 \\ 0 & 1 & 1 & -1 & 0 & 0 & -1 & 0 & 0 \\ 1 & -1 & 0 & 1 & -1 & 0 & 1 & -1 & 0 \\ 1 & 0 & -1 & 1 & 0 & -1 & 1 & 0 & -1 \end{pmatrix}$$

In fact, the matrix M is a magic square if and only if $A\vec{m} = 0$ with $m_{ij} \geq 0$ for all i, j .

The set $S_A = \ker(A) \cap \mathbb{Z}_{\geq 0}^{n \times n}$ is a monoid in $\mathbb{Z}_{\geq 0}^{n \times n}$. The problem is to find a minimal set of (additive) generators of S_A . This is solved by the determination of an Hilbert basis \mathbf{H} , i.e. a subset of S_A such that

- (a) every $M \in S_A$ can be written as $\sum_{i=1}^q c_i A_i$ with $c_i \geq 0$ and $A_i \in \mathbf{H}$,
(b) \mathbf{H} is a minimal set relatively to this condition.

In the case of S_A , an Hilbert basis is given by the six 3×3 -matrices:

$$A_1 = T_{13} = \begin{pmatrix} 0 & 0 & 1 \\ 0 & 1 & 0 \\ 1 & 0 & 0 \end{pmatrix} \quad A_2 = S = \begin{pmatrix} 0 & 0 & 1 \\ 1 & 0 & 0 \\ 0 & 1 & 0 \end{pmatrix} \quad A_3 = S^2 = \begin{pmatrix} 0 & 1 & 0 \\ 0 & 0 & 1 \\ 1 & 0 & 0 \end{pmatrix}$$

$$A_4 = T_{12} = \begin{pmatrix} 0 & 1 & 0 \\ 1 & 0 & 0 \\ 0 & 0 & 1 \end{pmatrix} \quad A_5 = T_{23} = \begin{pmatrix} 1 & 0 & 0 \\ 0 & 0 & 1 \\ 0 & 1 & 0 \end{pmatrix} \quad A_6 = I = \begin{pmatrix} 1 & 0 & 0 \\ 0 & 1 & 0 \\ 0 & 0 & 1 \end{pmatrix}$$

For every $M \in S_A$, one has

$$M = \sum_{i=1}^6 c_i A_i \quad c_i \in \mathbb{Z}_{\geq 0}$$

and the rows and columns are $s = \sum_{i=1}^6 c_i$. In fact the generators are not linearly independent:

$$A_1 + A_2 + A_3 = A_4 + A_5 + A_6 = \begin{pmatrix} 1 & 1 & 1 \\ 1 & 1 & 1 \\ 1 & 1 & 1 \end{pmatrix}$$

Then to the 6-uple of coefficients $c = (c_1, \dots, c_6)$ corresponds the monomial $x^c = x_1^{c_1} \dots x_6^{c_6}$ with the relation $x_1 x_2 x_3$ equivalent to $x_4 x_5 x_6$.

The 3×3 magic squares with sum s are in 1-1-correspondence with standard monomials of degree s (i.e. monomials of degree s non divisible by $x_1 x_2 x_3$).

As in the previous theory of toric varieties, one obtains the quotient ring

$$R = \mathbb{C}[x_1 \dots x_6] / \langle x_1 x_2 x_3 - x_4 x_5 x_6 \rangle$$

Let us denote by $\mathcal{A} = \{\vec{m}_1, \dots, \vec{m}_6\} \subset \mathbb{Z}^9$ the set of integer vectors corresponding to the 3×3 permutation matrices A_1, \dots, A_6 and

$$\phi_{\mathcal{A}} : (\mathbb{C}^*)^9 \rightarrow \mathbb{P}^5$$

the map defined by

$$t \mapsto (t^{\vec{m}_1}, \dots, t^{\vec{m}_6})$$

The corresponding toric variety $\text{Spec}(R)$ is $X_{\mathcal{A}} = V(x_1 x_2 x_3 - x_4 x_5 x_6)$.

As in [7], one deduces that the number of 3×3 magic squares with corresponding sum s is equal to

$$\binom{s+5}{5} - \binom{s+2}{5}$$

with the convention $\binom{a}{b} = 0$ if $a < b$. In particular, one recovers the previous examples.

References

- [1] **M. Audin** *The topology of Torus Actions on Symplectic manifolds*. Progress in Math. vol 93, Birkäuser, 1991.
- [2] **G. Barthel, J.-P. Brasselet et K.-H. Fieseler** *Classes de Chern des variétés toriques singulières*. C.R.Acad.Sci. Paris 315 (1992), 187–192.
- [3] **G. Barthel, J.-P. Brasselet, K.-H. Fieseler et L. Kaup** *Diviseurs invariants et homomorphisme de Poincaré des variétés toriques complexes*. Tôhoku Math. Journal 48 (1996), 363-390.
- [4] **G. Barthel, J.-P. Brasselet, K.-H. Fieseler und L. Kaup** *Divisoren und Schnitthomologie torischer Varietäten*. Banach Institute Publications, Vol. 36 (1996) 9-23.
- [5] **L.J. Billera and C. Lee** *A proof of the sufficiency of McMullen's conditions for f -vectors of simplicial polytopes*. J. Combinatorial Theory (A) 31 (1981), 237-255.
- [6] **J.L. Brylinski** *Eventails et Variétés Toriques*, Séminaire sur les singularités des surfaces, Lect. Notes in Math. 777 (1980), 247-288.
- [7] **D. Cox, J. Little and D. O'shea** *Using Algebraic Geometry* Graduate Texts in Mathematics, 185, Springer Verlag, 1998.
- [8] **V.I. Danilov** *The Geometry of toric Varieties*. Russian Math. Surveys 33 (1978), 97 - 154.
- [9] **M. Eikelberg** *Picard Groups of Compact Toric Varieties and Combinatorial Classes of Fans*. Results Math. 23 (1993), 251-293.
- [10] **G.Ewald** *Combinatorial convexity and Algebraic Geometry*. Graduate Texts in Mathematics. 168. 1996.
- [11] **W. Fulton** *Introduction to Toric Varieties*. Annals of Math. Studies, Princeton Univ. Press 1993.
- [12] **R. Hartshorne** *Algebraic Geometry*. Graduate Texts in Math. 52, Springer Verlag, New York etc., 1977.
- [13] **F. Hirzebruch** *Topological Methods in Algebraic Geometry*. Springer Verlag, 1966.
- [14] **M. McMullen** *On simple polytopes*. Invent. Math. 113 (1993), 419-444.
- [15] **T. Oda** *Convex Bodies and Algebraic Geometry*. Ergebn. Math.Grenzb. (3. Folge), Bd. 15, Springer-Verlag, Berlin etc., 1988.
- [16] **T. Oda** *Modern aspects of combinatorial structure on convex polytopes* (Kyoto, 1993). Sūrikaiseikikenkyūsho Kōkyūroku Kyoto University, Research Institute for Mathematical Sciences, Kyoto, 1994. No. 857 (1994), 99–112.
- [17] **M. Oka** *Non-degenerate complete intersection singularity* . Actualités Mathématiques. Hermann, Paris, 1997.
- [18] **O. Riemenschneider** *Deformationen von Quotientensingularitäten (nach zyklischen Gruppen)*. Math. Ann. 209 (1974) 211-248.
- [19] **R. Stanley** *The number of faces of a simplicial convex polytope*. Advances in Math., 35 (1980), 236 - 238.